

# MARTIN AUDIO CDD SERIES

## CDD SERIES USER GUIDE



## CONTENTS

|  |    |
|--|----|
| APPROVALS.....   | 4  |
| Unpacking the Unit.....  | 4  |
| INTRODUCTION.....  | 5  |
| Coaxial Differential Dispersion Technology.....                    | 6  |
| THE CDD RANGE.....   | 7  |
| CDD Range Accessories.....   | 8  |
| Mounting accessories.....  | 8  |
| Weatherised Versions.....  | 9  |
| CDD MOUNTING HARDWARE.....   | 10 |
| Wall and ceiling mounting brackets.....                            | 10 |
| Yoke assemblies.....   | 12 |
| Eye Bolts.....   | 12 |
| VERTICAL AND HORIZONTAL DEPLOYMENT.....                            | 13 |
| Grille removal and replacement.....                                | 14 |
| Badge rotation.....  | 16 |
| CHOOSING A MOUNTING LOCATION.....                                  | 17 |
| First and second fixing.....                                       | 18 |
| Wall mounting – procedure.....                                     | 19 |
| CDD5 only.....   | 19 |
| CDD6, CDD8, CDD10 and CDD12.....                                   | 24 |
| Ceiling mounting – procedure.....                                  | 28 |
| CDD5 only.....   | 28 |
| CDD6 and CDD8.....   | 31 |
| Mounting with a yoke assembly.....                                 | 34 |
| Flying CDD Series cabinets.....                                    | 38 |
| SX SERIES SUBWOOFERS - INSTALLATION.....                           | 40 |
| Flying SX sub-woofers.....   | 40 |
| SYSTEM CONNECTIONS.....  | 42 |
| WR (Weatherised) models only.....                                  | 42 |
| Impedances.....  | 43 |
| 70/100 V-line operation (Models CDD5TX-WR and CDD6TX-WR only)..... | 43 |
| Cable specifications.....  | 43 |
| System examples.....   | 44 |
| 1 x Stereo.....  | 44 |
| 2 x Stereo + 1 Sub.....  | 44 |
| 3 x Stereo + 2 Sub.....  | 45 |

|                                     |    |
|-------------------------------------|----|
| MARTIN AUDIO DX0.5                  |    |
| LOUDSPEAKER MANAGEMENT SYSTEM ..... | 46 |
| CDD Preset List .....               | 46 |
| Using alternative controllers.....  | 47 |
| Amplifiers – recommendations .....  | 48 |
| APPENDIX .....                      | 49 |
| Specifications.....                 | 49 |
| CDD5, CDD6, CDD8.....               | 49 |
| CDD10, CDD12, CDD15.....            | 50 |
| CSX112-F, CSX212-F.....             | 51 |
| CSX118-F, CSX218-F.....             | 52 |
| Technical Drawings .....            | 53 |
| CDD5.....                           | 53 |
| CDD6.....                           | 53 |
| CDD8.....                           | 54 |
| CDD10 .....                         | 54 |
| CDD12 .....                         | 55 |
| CDD15 .....                         | 55 |
| CSX112-F .....                      | 56 |
| CSX212-F .....                      | 56 |
| CSX118-F .....                      | 57 |
| CSX218-F .....                      | 57 |
| Speaker Brackets.....               | 58 |
| CDD5 Wall Bracket.....              | 58 |
| CDD5 Ceiling Bracket.....           | 59 |
| CDD6 & CDD8 Wall Bracket .....      | 60 |
| CDD6 & CDD8 Ceiling Bracket .....   | 61 |
| CDD10 & CDD12 Wall Bracket .....    | 62 |
| CDD15 Wall Bracket.....             | 62 |
| WARRANTY.....                       | 63 |
| COPYRIGHT AND TRADEMARKS .....      | 63 |

## APPROVALS



This equipment conforms to the requirements of the EMC Directive 89/336/EEC, amended by 92/31/EEC and 93/68/EEC and the requirements of the Low Voltage Directive 72/23/EEC, as amended by 93/68/EEC.

EMC Emission: EN55103-1:2009

EMC Immunity: EN55103-2:2009

Safety: IEC60065:2002 + A2:2010

## UNPACKING THE UNIT

Thank you for purchasing a Martin Audio CDD Series speaker system. Every Martin Audio loudspeaker is built to the highest standard and thoroughly inspected before it leaves the factory. After unpacking the system, examine it carefully for any signs of transit damage and inform your dealer if any is found. It is suggested that you keep the original packaging so that the system can be repacked at a future date if necessary. Please note that neither Martin Audio nor its distributors can accept any responsibility for damage to any returned product which arises through the use of non-approved packaging.



Please think of our environment.

When the product has reached the end of its useful life, please dispose of it responsibly through a recycling centre.

## INTRODUCTION

The Martin Audio CDD Series has been designed to fulfil the need for high performance sound in pubs, bars, restaurants, retail premises, nightclubs, conference facilities, theatres, educational institutions, places of worship, museums, exhibition centres and cruise ships, in an ultra-compact package.

CDD speakers deliver the highest quality audio over a wide area, with consistent coverage throughout the venue.

The cabinets are styled to be architecturally unobtrusive. CDD enclosures (except for the CDD5) are constructed from rigid, moulded UPM Formi, a fibre composite material combining stiffness with excellent damping properties. The larger models (CDD8 upwards) have birch ply baffles and all models feature flush, acoustically transparent steel grilles. Subwoofers are built in heavily braced MDF enclosures. Enclosures come in either a white or black finish; with other RAL colours available to order.

The CDD range of loudspeakers use two-way, full-range co-axial drivers, incorporating Martin Audio's exclusive Differential Dispersion™ horn technology. Passive crossovers optimised for the drivers are fitted, obviating the need for bi-amping. The crossover frequency is between 1.6 kHz and 2.5 kHz, depending on model.

The CDD range consists of six full-range units, with drivers from 5" to 15". These are supplemented by a range of four SX sub-woofers with single or dual 12", or single or dual 18" LF drivers. Systems may be used individually or in multiples to suit a wide variety of applications. Link connectors are fitted to facilitate daisy-chain wiring.

Versions of the CDD5 and CDD6 are also available for 70/100 V-line operation. These models, the CDD5TX and CDD6TX respectively, include a high quality tapped transformer and a power setting switch, to allow the speakers to be used with the 70 V-line or 100 V-line distribution systems used for announcements and background music in office complexes, hotels and similar large buildings.

A wide range of installation accessories is also available, permitting wall, ceiling or flown mounting. Mounting hardware is suitable for first and second fix construction industry conventions.

All CDD and SX models may also be ordered as weatherproof (WR) versions: these are suitable for deployment in locations where they may be subject to moisture (e.g., swimming pools, near water features, etc.), or rainfall. CDD-WR models are rated IP54, while SX-WR models are rated IP24.

This User Guide provides a detailed explanation of the CDD's features and options. Thanks for taking the time to look through this Guide.

## COAXIAL DIFFERENTIAL DISPERSION TECHNOLOGY

All CDD Series full-range models feature Martin Audio's unique, patent-pending Coaxial Differential Dispersion™ technology. CDD systems augment the 'point-source' benefits of coaxial drivers with the consistency of coverage which Differential Dispersion technology can deliver.

Non-coaxial systems can suffer from uneven frequency response in the crossover region because of interference between the LF and HF sections; depending on the listening position, this causes off-axis variations, particularly close to the loudspeaker. In contrast, coaxial systems aim to sum LF and HF contributions at all positions off-axis, even close-up.

A disadvantage of conventional coaxial devices can be HF beaming, where the HF dispersion reduces at higher frequencies. This is primarily because the HF energy emerges through a narrow tube in the pole-piece of the magnet system. CDD Series coaxial devices overcome this by the use of a static waveguide that merges seamlessly with the unique cone shape — maintaining the dispersion pattern even at very high frequencies.

A Differential Dispersion horn has a trapezoidal dispersion pattern in both vertical and horizontal planes which covers the target area more evenly than a system with a conventional, fixed-dispersion type horn. With a conventional horn, the speaker is usually placed above head height and aimed towards the centre of the audience. This produces an imperfect coverage pattern which misses out some areas — particularly side areas close to the loudspeaker.

In contrast, a CDD Coaxial Differential Dispersion system produces a rectangular coverage pattern extending to all corners of the audience area, while wide horizontal coverage is achieved very close to the loudspeaker. The consistency of frequency response and SPL thus achieved throughout the audience area is exceptional. The improved coverage close to the source also means that CDD speakers can often be spaced further apart, reducing overall speaker count.

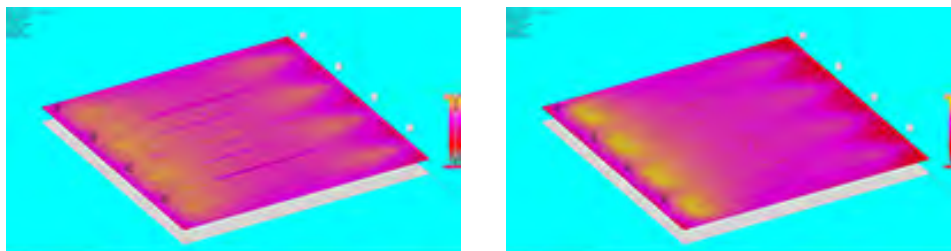

The two EASE plots shown above illustrate the coverage obtained from four CDD speakers (on the left of the plot) as compared with that obtained from four equivalent Martin Audio AQ Series speakers (on the right). The plots are taken at 4 kHz (left) and 8 kHz (right), with all other measurement parameters remaining constant. It can be seen that the CDD coverage is significantly more even across the width of the audience area at these important mid-range frequencies.

## THE CDD RANGE



The CDD range consists of six full-range systems and four sub-woofers (the SX Series), as summarised below. Please refer to “Specifications” on page 49 for full technical specifications for each model.

### Full-range systems:

|          | Model | LF driver (dia.) | HF driver (dia.) | LF -3 dB point | Power rating |
|----------|-------|------------------|------------------|----------------|--------------|
| <b>A</b> | CDD5  | 5" (125 mm)      | 0.7" (19 mm)     | 100 Hz         | 100 W        |
| <b>B</b> | CDD6  | 6.5" (165 mm)    | 1" (25 mm)       | 80 Hz          | 150 W        |
| <b>C</b> | CDD8  | 8" (200 mm)      | 1" (25 mm)       | 70 Hz          | 200 W        |
| <b>D</b> | CDD10 | 10" (250 mm)     | 1" (25 mm)       | 65 Hz          | 250 W        |
| <b>E</b> | CDD12 | 12" (300 mm)     | 1" (25 mm)       | 62 Hz          | 300 W        |
| <b>F</b> | CDD15 | 15" (380 mm)     | 1.4" (35 mm)     | 55 Hz          | 400 W        |

### Subwoofers:

|          | Model | LF driver (dia.) | LF -3 dB point | Power rating |
|----------|-------|------------------|----------------|--------------|
| <b>G</b> | SX112 | 1 x 12" (250 mm) | 48 Hz          | 400 W        |
| <b>H</b> | SX212 | 2 x 12" (250 mm) | 48 Hz          | 800 W        |
| <b>I</b> | SX118 | 1 x 18" (460 mm) | 40 Hz          | 1000 W       |
| <b>J</b> | SX218 | 2 x 18" (460 mm) | 35 Hz          | 2000 W       |

Colour coding - all CDD and SX models are available in:

- white – suffix ‘W’ is added to model number
- black – suffix ‘B’ is added to model number
- custom RAL colour – suffix ‘RAL’ is added to model number

All CDD and SX models may be ordered with factory-fitted weatherproofing, for use in moisture-prone locations; add “-WR” to model number.

The weatherproofed versions of Models CDD5 and CDD6 are also suitable for connection to 70 V-line or 100 V-line speaker distribution systems (but can also be used with low impedance systems). These versions are designated CDD5TX-WR and CDD6TX-WR respectively.



**NOTE:** All information in this User Guide applies equally to “standard” and “WR” versions unless specifically stated to the contrary. Similarly, the “TX-WR” versions of the CDD5 and CDD6 may be assumed to be identical to the standard versions unless stated otherwise.

## CDD RANGE ACCESSORIES

### Mounting accessories

Several mounting options are available for the various models in the CDD range:

- Wall mounting brackets are available for all CDD models.
- Ceiling mounting brackets are available for CDD5, CDD6 and CDD8.
- Yoke assemblies are available for CDD10, CDD12 and CDD15. Yoke assemblies are suitable for either wall or ceiling mounting.
- CDD10, CDD12 and CDD15 may be flown using standard rigging procedures; these three models use the same eye bolts. Note that SX subwoofers may also be flown (see “SX Series subwoofers - installation” on page 40).

Brackets and yoke assemblies are available in black or white to match the standard enclosure finishes.

**NOTE:** A venue with Martin Audio AQ Series speakers already installed may be easily upgraded to CDD Series speakers in many cases, as some of the existing AQ Series wall and ceiling mounting brackets may be retainable and re-usable; the mounting holes in the enclosure fixing plates are compatible with the CDD series. (Note that this does not apply to all models.)



## WEATHERISED VERSIONS

All CDD and SX models are available with factory-fitted weather proofing components: these may be denoted by the suffix “-WR” to the model number. Weatherised versions are available in both black and white finishes.

Weatherised versions of CDD cabinets include two additional layers of protection behind the front grille: first there is a Declon® (synthetic fibre) layer, below which there is a secondary zinc-plated steel grille assembly with a hydrophobic (water-repellent) coating and a rubber edge extrusion. The LF driver cone itself is also treated with a hydrophobic coating. The rear connection panel is protected by a gasketed cover with a cable gland, and the fixing points are of stainless steel. These constructional differences allow the WR versions to meet environmental testing to IP Rating IP54.

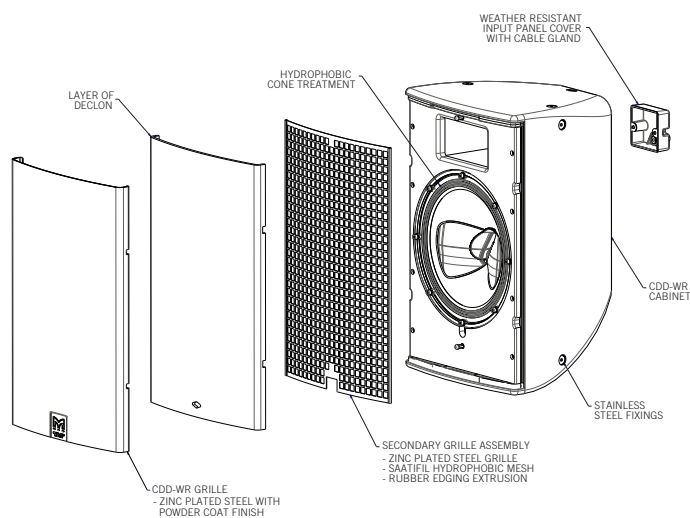

Weatherised versions of SX subwoofers feature similar protection for the rear connection panel, stainless steel fixing points, and zinc-plated front grilles. They are tested to meet environmental rating IP24.

## CDD MOUNTING HARDWARE

### WALL AND CEILING MOUNTING BRACKETS

All CDD models can be wall mounted using a wall bracket (supplied with CDD5, optional for other models). CDD5, CDD6 and CDD8 can be ceiling mounted using an optional ceiling bracket. CDD10, CDD12 and CDD15 can be wall or ceiling mounted using an optional yoke assembly – see page 12.

All CDD wall and ceiling brackets allow the enclosures to be mounted in either vertical (“portrait”) or horizontal (“landscape”) orientation. **For horizontal orientation, you must rotate the driver. For details, see page 13.**

The wall mounting brackets include pan and tilt adjustments to permit optimum alignment, while the ceiling brackets for CDD6 and CDD8 allow the vertical tilt angle to be set. Brackets are supplied with fixing screws to secure the bracket to the cabinet. To help installers complete a neat fitment, the fixing plate of all the brackets includes a 19 mm diameter cable access hole for the connection(s).

**NOTE:** To assist with first fix installation, see the drawings for the ceiling and wall mounting brackets in the Technical drawings section of this Guide, see page 58.

#### Model CDD5:

**NOTE:** Model CDD5 speakers are packed and shipped in pairs, complete with wall mounting brackets finished in either black or white to match the speakers. CDD5s in custom RAL colours will be supplied with black brackets. No additional mounting hardware is required if the speakers are to be wall mounted.

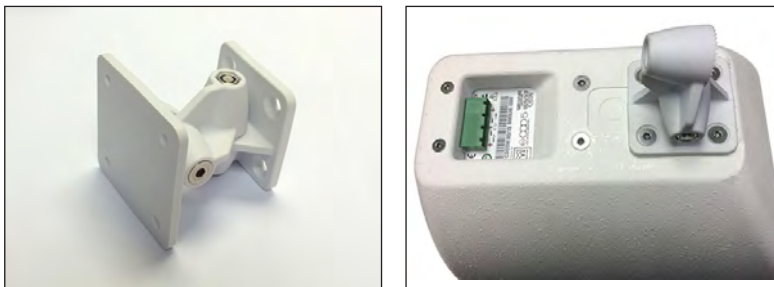

#### Ceiling bracket – Part Nos. CDDCB5B (black), CDDCB5W (white):

Model CDD5 speakers may alternatively be ceiling mounted using these optional brackets, which mate with one part of the wall mounting brackets supplied with the speakers.

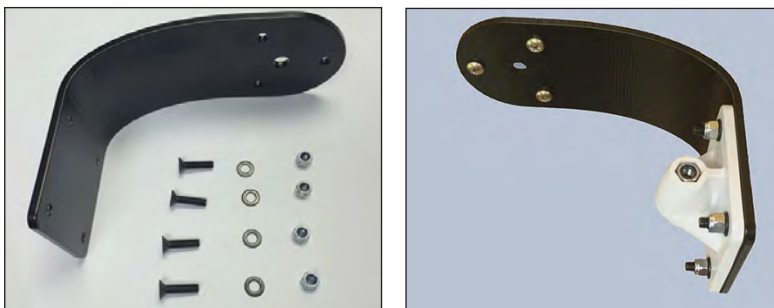

**Models CDD6 and CDD8:**

These two models use the same wall and ceiling brackets.

**Wall bracket – Part Nos. WB6/8B (black), WB6/8W (white)**

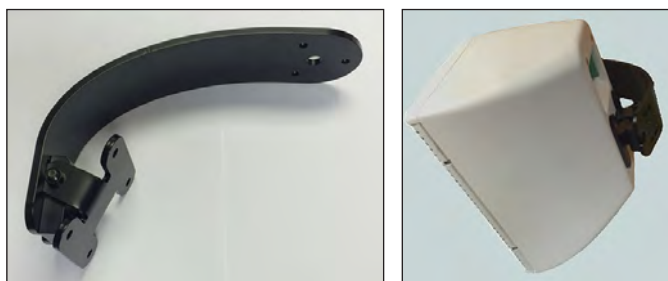

**Ceiling bracket – Part Nos. CDDCB6/8B (black), CDDCB6/8W (white)**

**Models CDD10 and CDD12:**

These two models use the same wall brackets. These brackets are identical in design to the brackets for the CDD6 and CDD8 pictured above. They are just stronger, larger and heavier.

**Wall bracket – Part Nos. WB10/12B (black), WB10/12W (white)**

**Model CDD15:**

This model uses a bracket that is similar in design to the brackets for the CDD6 and CDD8 shown above. The CDD15 bracket is stronger, larger and heavier than the brackets for CDD10 and CDD12 and is attached to the wall with six screws rather than four.

**Wall bracket – Part Nos. WB15B (black) and WB15W (white)**

## YOKE ASSEMBLIES

Yoke assemblies are available for the CDD10, CDD12 and CDD15.

For fixed installations, the yoke assembly may only be installed horizontally, which allows tilt adjustment. Two fixing holes are provided in the main strut for this purpose.

Alternatively, if the cabinet is to be suspended from a scaf pole or other standard rigging, the yoke may be fitted with a half-coupler clamp using a third (centrally-located) 13 mm diameter hole in the yoke's main strut. Only horizontal orientation is possible with this method.

**See page 13 for important information regarding driver rotation for use in horizontal orientation.**

The yoke assemblies for the CDD10, CDD12 and CDD15 are identical in design. The pictures below show the yoke assembly for the CDD12.

### Model CDD10:

Yoke Assembly CDDYA10B (black), CDDYA10W (white)

### Model CDD12:

Yoke Assembly CDDYA12B (black), CDDYA12W (white)



### Model CDD15:

Yoke Assembly CDDYA15B (black), CDDYA15W (white)

## EYE BOLTS

Models CDD10, CDD12 and CDD15 may be flown using optional eye bolts

**Shouldered Eye bolts, Part No. HTKCT05 (8 mm diameter)**



## VERTICAL AND HORIZONTAL DEPLOYMENT

CDD speakers are shipped from the factory ready for deployment in vertical – or “portrait” – orientation. If the installation favours horizontal orientation, the coaxial driver must be rotated through 90° to maintain the correct dispersion patterns. Inadequate coverage and generally sub-optimal performance will result from mounting a CDD speaker with the driver incorrectly orientated.



It can be seen from the above views that the CDD's coaxial driver is not symmetrical. For correct performance, the driver should always be orientated as shown, with the “butterfly wings” of the HF driver assembly biased towards the bottom of the enclosure. A graphic can be found on the rear of the cabinet to confirm the correct orientation:

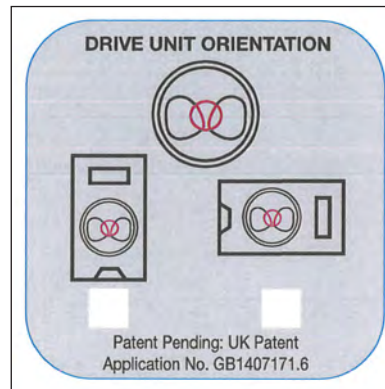

To rotate the driver, proceed as follows:

1. Place the enclosure face-up on a bench, table or other suitable flat surface.
2. Follow the instructions for grille removal in the section below “Grille removal and replacement”.
3. Using a No. 2 Pozi screwdriver (CDD5) or a hex key (CDD6: 2.5 mm AF; CDD8/10: 4 mm AF; CDD12/15: 5 mm AF), remove the screws securing the driver to the baffle board. There will be between four and eight screws depending on the particular CDD model.
4. Gently lift the driver assembly out, rotate it through 90° and replace it.
5. Refit the screws removed in Step 3.
6. Follow the instructions for grille replacement in the section below “Grille removal and replacement”.
7. Follow the instructions in the section below “Badge rotation”.

Note that if, for any reason, it is necessary to mount the CDD speaker in portrait mode “upside-down”, the driver must be rotated through 180° using the same procedure described above.

## GRILLE REMOVAL AND REPLACEMENT

Grilles on CDD Series cabinets are designed to be easy to remove to facilitate driver rotation. No screws are used to hold them in place; they are manufactured with a natural spring which holds them in place in slots in each side of the cabinets. The grilles have two or three gaps in the sides into which an appropriately-sized flat-bladed screwdriver can be inserted to assist in removal.

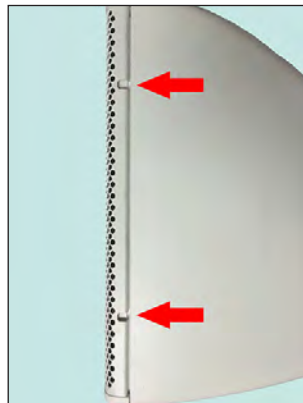

Insert the screwdriver blade into one of the gaps - either at the top or bottom of the cabinet (don't start in the middle).



Push the handle down. This will lift the grille out of the slot.

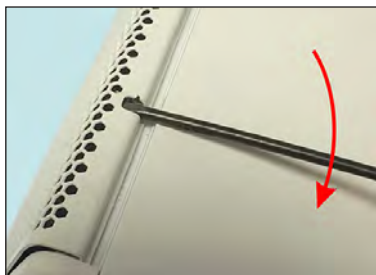

Now lift the handle up; this will ease the grille forward slightly to prevent the return on the grille dropping straight back into the slot:

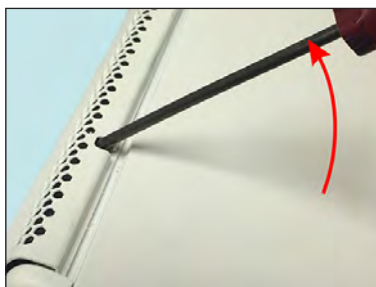

Repeat this process for the remaining gaps in the grille to ease it out of the slot all the way up one side of the cabinet; when you get to the final gap the grille should pop out and away from the front of the cabinet.

To replace the grille, first insert one side into the slot on one side of the cabinet. Make sure the return on the grille is completely engaged in the slot. Push on the front of the grille with the flat of your hand, which will encourage the other edge of the grille to locate on the side of the cabinet close to the slot. Now push the edge of the grille back starting at the top or the bottom to engage the return in the slot; you may need to do this a little at a time, working down the length of the grille until it pops into place.



## BADGE ROTATION

The badge can also be removed and rotated. It has mouldings on the mounting spigot to ensure that it can only be repositioned in one of four positions (90° apart). It is recommended that you change the badge position at the same time as the grille is removed to rotate the driver. On the back of the grille you will see the badge mounting spigot showing just above the plastic fitting into which it locates:



Push down on the spigot with your thumb (or use the flat face of a suitable tool if necessary)...

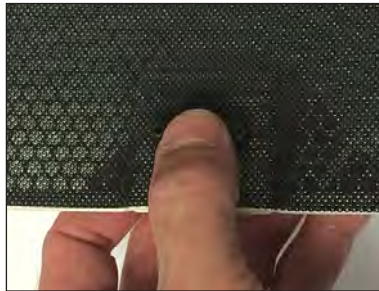

...and the badge will pop out of the housing:

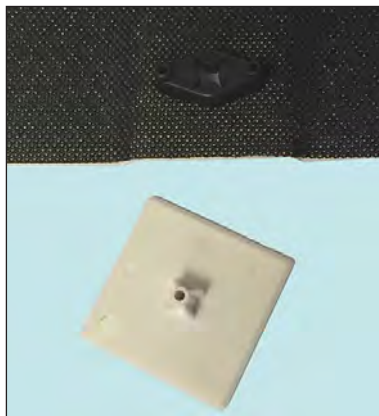

It can be rotated 90 or 180° to suit the cabinet deployment and pushed back into place. It is simply held in place through friction so push it firmly in place to ensure that it doesn't fall out.



## CHOOSING A MOUNTING LOCATION

CDD Series loudspeakers should be mounted above head height – high enough to clear peoples' heads for clean coverage but low enough to avoid over-exciting room resonances.

Tilt angles should be set so that the loudspeaker's maximum output (usually on-axis of the loudspeaker centre) is aimed at the furthest listener across the room.

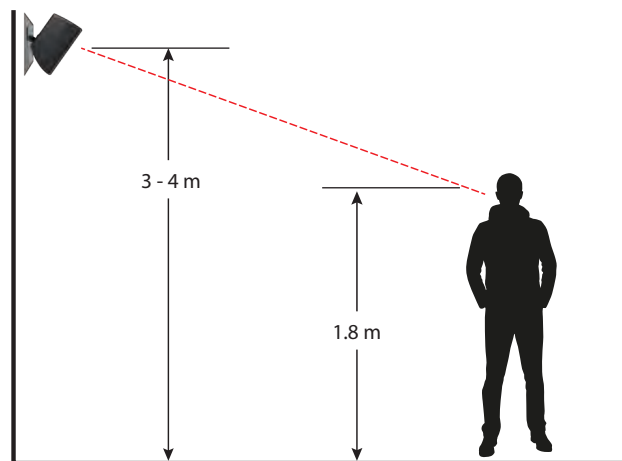

The horizontal dispersion pattern of CDD Series speakers tends towards a square due to the design of the coaxial driver. For this reason, mounting speakers in the corner of rooms should be avoided.

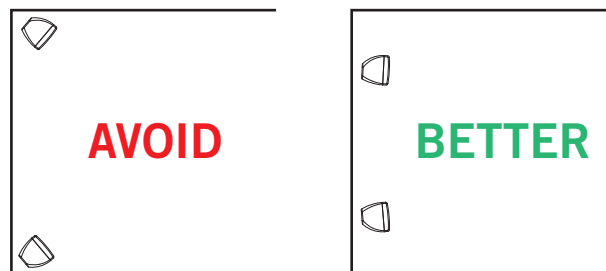

**NOTE:** Care should be taken when co-locating CDD Series speakers, either adjacently or in an array. Due to the Differential Dispersion characteristics if two (for example) CDD speakers are placed adjacent to each other, there may be an overlap in horizontal coverage in part of the intended area, which could lead to unwanted comb filtering.

### EASE data

To assist system design and speaker placement within a venue, high-resolution GLL files for CDD Series models may be downloaded from the Martin Audio website: [www.martin-audio.com](http://www.martin-audio.com)

## FIRST AND SECOND FIXING

Construction industry practice frequently favours “first” and “second” fixing stages. This system gives installers the advantage of being able to pull cables and make primary fixings at an earlier stage of building completion, and avoids the potential problems of leaving expensive and delicate audio equipment in-situ while building and decoration work is still on-going.

All CDD Series mounting brackets – wall, ceiling and yokes – disassemble into separate “first fix” and “second fix” components. This means that part of the bracket may be secured to the wall or ceiling at first fix, without the necessity of having the cabinet on site. The rest of the bracket can then be fitted to the cabinet at floor level at second fix, and then the two parts of the bracket easily mated.

The two fixing stages may be summarised as follows:

**First stage fixing** – Fix “first fix” sections of wall or ceiling brackets at desired locations. Run speaker cables to speaker locations, using cable access holes provided in brackets. If using yoke assemblies for a fixed installation, fit the main yoke in position; in this case the large diameter centre hole provided for a scaf clamp may be used as an access hole for the cable(s).

### **IMPORTANT INFORMATION**

**Consult a qualified structural engineer with a full knowledge of the building, its load ratings and your intended loudspeaker installation plans before commencing any installation. The type and size of fixings used must take into account both the weight of the enclosure and the construction of the wall or ceiling.**

**Second stage fixing** – Attach “second fix” sections of brackets to rear of cabinets. For yoke assemblies, fit strap bars to cabinet. Raise cabinets to height and mate with first fix bracket sections. Connect up in all cases. Adjust pan and/or tilt as required.

### **IMPORTANT INFORMATION**

**In some cases, local regulations may require a safety bond (e.g., wire or chain) to form part of the final fix. The complete installation should be checked and approved by a qualified structural engineer and a qualified electrical safety consultant before being signed off.**

## WALL MOUNTING – PROCEDURE

### CDD5 only

We supply each pair of CDD5 speakers with a pair of wall brackets. If you need to replace these wall brackets, the codes are ASM10001 for the white bracket or ASM10002 for black. The bracket is a three-part design which allows adjustment in both horizontal and vertical planes as required.

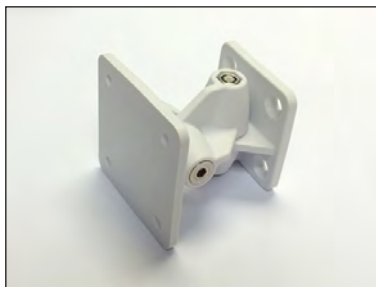

### **First fix:**

First decide whether adjustment is needed in one or both planes, and then disassemble the bracket. To obtain both horizontal and vertical adjustment, separate the wall section of the bracket using a 4 mm hex key. The wall section is easily identified as it has the larger flange with fixing holes on 45 mm centres; the cabinet section is smaller and has countersunk holes on 35 mm centres.



If only one plane of adjustment is required - either vertical or horizontal - remove the link section in the middle; this is also secured with a 4 mm hex head bolt.



Fit the wall bracket in the orientation shown below for operation with adjustment in two planes, or for horizontal adjustment only:



If only vertical adjustment is required, fit as shown below:



Fixings appropriate for the wall surface and weight of the cabinet (2.7 kg) must be used to ensure a safe and secure installation. It is good practice to terminate the speaker cables with the mating Phoenix connectors (supplied with the cabinets) at this stage.

If second fix is to follow at a later date, it is a good idea to screw the pivot bolt into the wall bracket so it does not get lost.

### **Second fix:**

The CDD5 may be mounted in either “portrait” (vertical) or “landscape” (horizontal) orientation. This decision is purely based on the desired visual impact in the space in which the speakers are being installed.

Note that it is vital that the driver is orientated to suit the deployment used. “Out of the box” the driver is in the correct position for “portrait” use and must be rotated through 90° for “landscape” use. Please see page 13 for details of driver rotation.

For “portrait” use, the cabinet bracket section is attached using the four “lower” fixing points:



For “landscape” use, the four “upper” fixing points (as viewed in portrait orientation) must be used:



The cabinet bracket section must be attached in an orientation to suit the desired degree of adjustment. First remove the four screws using a 3 mm hex key. For installation with two planes of adjustment, or vertical adjustment only, the cabinet bracket must be attached as shown below:



If only horizontal adjustment is required, the bracket section should be fitted like this:



(Note that the two pictures above assume portrait orientation.)

Fix the bracket in place using the screws removed from the cabinet. Tighten these securely.

Remove the pivot bolt from the wall bracket section. Offer the speaker up to the wall bracket section; if this is in the vertical position as at page 19, the cabinet bracket section or link bracket will hook securely in place, freeing up both hands for re-fitting the securing bolt:



If the wall bracket is in the horizontal position (allowing only vertical adjustment), simply slide the two sections of the bracket together and insert the pivot bolt while supporting the speaker with the other hand. The link section of the bracket assembly is not required for this mounting option.



Do not fully tighten the bolt at this stage, leave a little play to allow final adjustment. If the fitment includes the link bracket, this may also be loosened slightly for final adjustment. The CDD5 can now be positioned using the locating radial teeth on the bracket to hold it in position, these will allow adjustment in increments of approximately 10° in both horizontal and vertical planes. Final adjustment is best done with an audio source to check the coverage. When the final position is found, tighten the securing bolt(s).



### CDD6, CDD8, CDD10, CDD12 and CDD15

The WB6/8 is a two-part wall bracket comprising a wall mounted spigot and a cabinet bracket holding a collar which secures onto the spigot. The same bracket fits both the CDD6 and CDD8 cabinets. The WB10/12 wall bracket for the CDD10 and CDD12 is of very similar design, but is larger and stronger to cater for the greater weight. The WB15 for the CDD15 is even larger and heavier. The fitting procedure for all these brackets is the same.



#### **First fix:**

The two sections of the bracket should be separated as shown below.

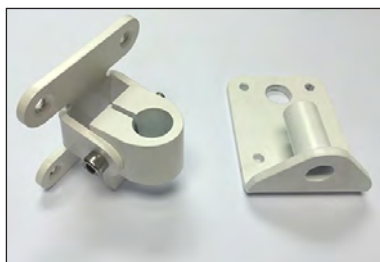

The wall section of the bracket may be attached at first fix stage prior to bringing the speakers to site. It is also good practice to terminate the speaker cables with the Phoenix connectors at this stage. Fixings appropriate for the wall surface and weight of the cabinet must be used to ensure a safe and secure installation; this is particularly important for the larger cabinets as the CDD 12 (for example) weighs 19.3 kg. It is vital to use fixings that are rated to support the weight of the cabinet being installed.



**Second fix:**

The cabinet bracket section should be attached as shown. Screw the vertical adjustment grub screw all the way in to allow the collar to lift clear of the spigot.



The speaker may be wall mounted in either “portrait” (vertical) or “landscape” (horizontal) orientation. This decision is purely based on the desired visual impact in the space in which the speaker is being installed.

Note that it is vital that the driver is orientated to suit the deployment used. “Out of the box” the driver is in the correct position for “portrait” use and must be rotated through 90° for “landscape” use. Please see page 13 for details of driver rotation.

For “portrait” use, the cabinet bracket is attached using the four “lower” fixing points:



For “landscape” orientation, use the upper four fixing points:

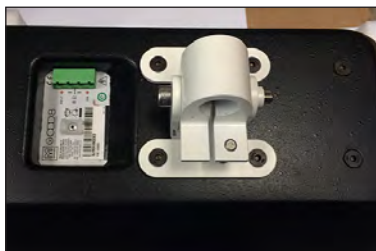

**NOTE:** The CDD6 has only four fixing points instead of the six found on the CDD8, CDD10 and CDD12. The same four points should be used in either orientation.

First remove the four screws using a 4 mm hex key (CDD6/8) or a 5 mm hex key (CDD10/12). Align the bracket with the fixing holes and screw securely in place using the same screws.

**NOTE:** the cabinet and bracket shown in these examples are deliberately in different colours for reasons of clarity.

Offer the speaker up to the wall bracket; the collar on the cabinet bracket section will hook securely in place on the spigot, freeing up both hands for final adjustment.



Horizontal (pan) adjustment is available by rotating the collar on the spigot. When you're happy with the angle, the collar securing bolt can be tightened with an M6 hex key (WB8/6) or an M8 hex key (WB10/12 and WB15) to lock the position.



Vertical (tilt) adjustment is made by adjusting the grub screw:



## CEILING MOUNTING – PROCEDURE

### CDD5 only

The optional CDDCB5(B or W\*) ceiling bracket may be used in conjunction with the wall brackets supplied with the CDD5 speakers to mount the CDD5s on a ceiling.



\* B and W suffixes denote colour

### **First fix:**

As with wall mounting, first decide whether adjustment is needed in one or both planes, and then disassemble the wall bracket. In most cases vertical adjustment only will be needed, as horizontal adjustment will be obtained by mounting the ceiling bracket at the correct angle. For vertical adjustment only, remove the link section of the wall bracket. If both horizontal and vertical adjustment is required, separate the wall section of the bracket using a 4 mm hex key. The wall section is easily identified as it has the larger flange with fixing holes on 45 mm centres; the cabinet section is smaller and has countersunk holes on 35 mm centres.

Now bolt the wall section of the bracket to the ceiling bracket using the four M5 screws, plain washers and Nyloc nuts supplied with the ceiling bracket. (Note that although the ceiling bracket is available in black or white and you would usually select the colour to match the cabinet, we have used a black bracket with a white CDD5 for better contrast in our photographs.)



The ceiling bracket assembly may now be fixed to the ceiling. There are three 5.5 mm holes and a central 8.5 mm hole in the bracket for this purpose. It is essential that appropriate fixings are used to allow safe and secure attachment to the ceiling material, particularly as these may be fitted overhead public areas. The method of fixing will depend on the ceiling construction. You can use the larger central 8.5 mm hole as the principal fixing initially: this lets you adjustment the bracket to obtain the correct horizontal coverage by pivoting it on the single mounting. When the position is correct, tighten it, and add further fixings to the other three holes to ensure a safe and secure mounting. Alternatively, if an adequate fix can be obtained using the three smaller holes alone (e.g., by using wood screws into a batten above plasterboard), it may be possible to use the 8.5 mm centre hole for cable routing.

In any case, it is good practice to terminate the speaker cables with the Phoenix connectors at this stage.



### **Second fix:**

With ceiling mounting, the CDD5 will probably be used in landscape mode: fit the cabinet section of the wall bracket using the four “upper” screws as shown below:



Note that it is vital that the driver is orientated to suit the deployment used. “Out of the box” the driver is in the correct position for “portrait” use and must be rotated through 90° for “landscape” use. Please see page 13 for details of driver rotation.

It is also possible to ceiling mount the CDD5 in portrait mode by using the “lower” four screws to fix the cabinet section of the wall bracket, but in this case the cabinet should be mounted upside down, and the driver and grille will both need to be rotated 180°. The sloping bottom of the cabinet allows a close fit to the ceiling which may be more aesthetically pleasing in some installations.





Offer the cabinet up to the ceiling bracket assembly and attach it using the 5 mm securing bolt. This can be loosely fitted to allow final adjustment before being fully tightened once the desired coverage has been established.



### CDD6 and CDD8

Optional mounting CDDCB6/8(B or W\*) is a bracket onto which allows a CDD6 or CDD8 cabinet to be ceiling mounted. It consists of two sections: a 90° arm and a removable four-point cabinet bracket section which is fixed directly to the cabinet rear:



\* B and W suffixes denote colour

#### **First fix:**

First disassemble the bracket, unscrewing the cabinet section from the ceiling arm using an M6 hex key to undo the securing bolt.



Fix the ceiling bracket assembly to the ceiling. There are three 6.5 mm holes and a central 13 mm hole in the bracket for this purpose. It is essential that appropriate fixings are used to allow safe and secure attachment to the ceiling material, particularly as these may be fitted overhead public areas. The fixings to be used will depend on the ceiling construction. Use the larger central 13 mm hole as the principal fixing initially: this lets you adjustment the bracket to obtain the correct horizontal coverage by pivoting it on the single mounting. When the position is correct, tighten it, and add further fixings to the other three holes to ensure a safe and secure mounting.

It is also good practice to terminate the speaker cables with the Phoenix connectors at this stage.



### **Second fix:**

With ceiling mounting, the cabinet will probably be used in landscape mode. Fit the cabinet section of the wall bracket (previously removed from the arm). The bracket is attached orientated as shown by removing four screws with an M4 hex key and attaching the bracket with the same screws. In the case of the CDD6, there are only four fixing points; the CDD8 has six: use the four “upper” ones. The photo below illustrates the fixings on a CDD6:



Note that it is vital that the driver is orientated to suit the deployment used. “Out of the box” the driver is in the correct position for “portrait” use and must be rotated through 90° for “landscape” use. Please see page 13 for details of driver rotation.

Offer the cabinet up the ceiling bracket arm and mate the cabinet bracket section with the ceiling bracket arm by threading the M6 bolt with spring washer through the cabinet bracket as shown below. Do not fully tighten the bolt at this stage, leave a little play so the vertical dispersion can be adjusted.

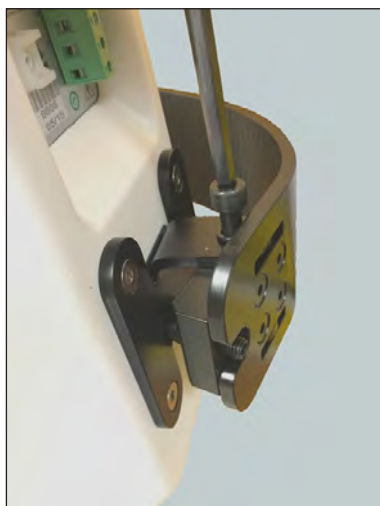

The vertical dispersion can be adjusted using the grub screw accessed from the rear of the bracket:

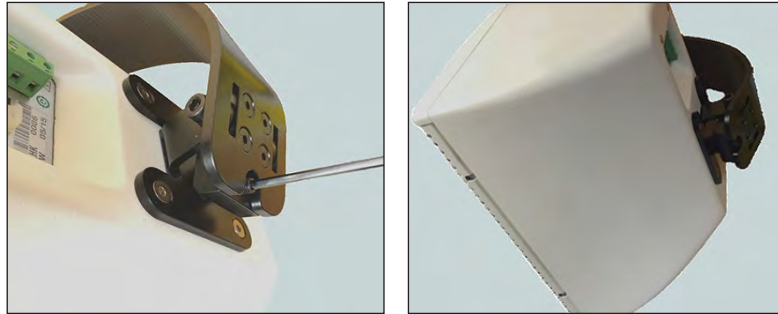

It is also possible to ceiling mount the CDD6 or CDD8 in portrait mode, but in this case the cabinet should be mounted upside down, and the driver and grille will both need to be rotated 180°. The sloping bottom of the cabinet allows a close fit to the ceiling which may be more aesthetically pleasing in some installations.



The cabinet section of the wall bracket should be fitted at 90° relative to the fitment used for landscape orientation. In the case of the CDD8, which has six rear fixing points, use the four “lower” ones; the CDD6 only has four fixing points.

## MOUNTING WITH A YOKE ASSEMBLY

As an alternative to wall brackets, for CDD10, CDD12 and CDD15 you can use yoke assemblies CDDYA10, CDDYA12 and CDDYA15 respectively.

The yoke design and fitting method is the same for all three models; the yoke assemblies differ only in size.

The assembly comes in three parts – the yoke itself, and two side bars which are bolted to the enclosure ends. If the yoke assembly is being fitted to a wall or ceiling as a permanent installation, first and second fix procedures may be adopted as described below. If the cabinet is to be hung in horizontal orientation from a pole with a scaf clamp, the yoke assembly can be fitted to the cabinet in a single operation.

### Installation:

Yokes may either be permanently fixed to a wall or ceiling, or fitted with a clamp for suspension from a scaf pole. The yokes are designed for use with cabinets in landscape orientation only; they do NOT support portrait orientation.

For permanent installations, a first fix/second fix method may be adopted; here the yoke loop is fixed in position and the cabinet mated to the loop at a later date, after being fitted with the rest of the yoke assembly.

When suspending the cabinet from a scaf pole, the whole yoke assembly should be fitted to the cabinet and the cabinet hung as a single exercise. In this case, the “First fix” section of the Installation instructions below may be ignored.

The components of the yoke assembly are shown below:

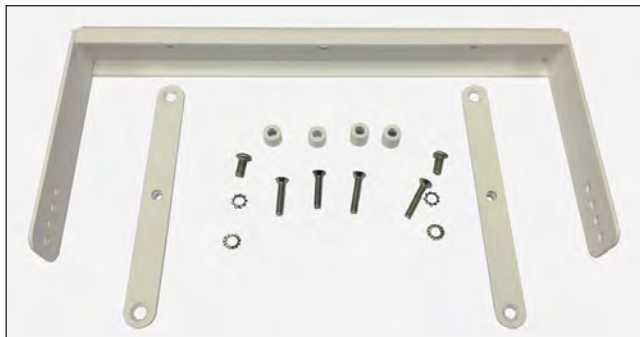

### First fix:

Yokes may be permanently attached to a wall or ceiling. The yoke allows vertical adjustment and if mounted using the single attachment point in the centre of the yoke horizontal adjustment could also be possible.

The yoke loop (the main, U-shaped part of the assembly) should be fitted to the wall or ceiling in its intended position. Four 8.5 mm holes are provided for this purpose. It is essential that appropriate fixings are used to allow safe and secure attachment to the ceiling material, particularly as these may be fitted overhead public areas. The central 13mm hole can also be used to mount the yoke which will provide horizontal adjustment as well as vertical; however, a sufficiently robust fixing method must be used if attaching from this single point and we would strongly recommend the use of a secondary safety fitting (see note in “Second fix” below). If not used for fixing, the central hole may be used for cable access. It is also good practice to terminate the speaker cables with the Phoenix connectors at this stage.



### **Second fix:**

CDD cabinets may only be used with yokes in horizontal (“landscape”) mode.

Note that it is vital that the driver is orientated to suit the deployment used. “Out of the box” the driver is in the correct position for “portrait” use and must be rotated through 90° for “landscape” use. Please see page 13 for details of driver rotation.

First remove two of the M8 screws in the top and bottom of the cabinet. Note that there are three screws on both top and bottom; the screw nearest the back of the cabinet is not used, so should be left in place.



The screws removed may be discarded; they should not under any circumstances be used to secure the yoke as they are of insufficient length for a safe fixing. Only use the longer screws supplied with the yoke assembly.

Next mount the side bars to the top and bottom of the cabinet. The two side bars included in the yoke assembly are identical but the correct screws and spacers must be used at each end. Two lengths of M8 socket head countersunk screw are supplied: 40 mm and 45 mm; there are also two pairs of spacer bushes, of different thicknesses. The longer screw and the thicker bush **MUST** be used with the bar on the bottom of the cabinet: this can be identified as the face with the steep sloping contour.

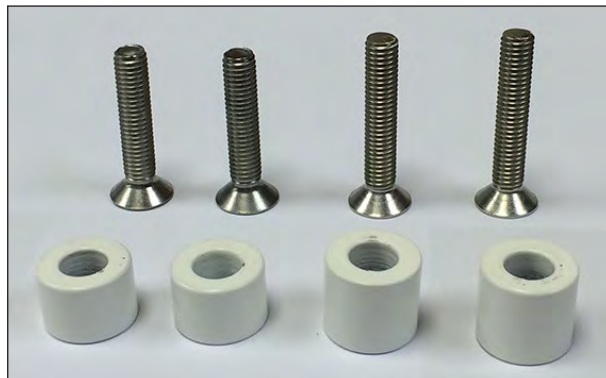

Mount the bars with the countersinks for the M8 fixing bolts facing outwards, so that the captive nut in the centre is facing in towards the cabinet.

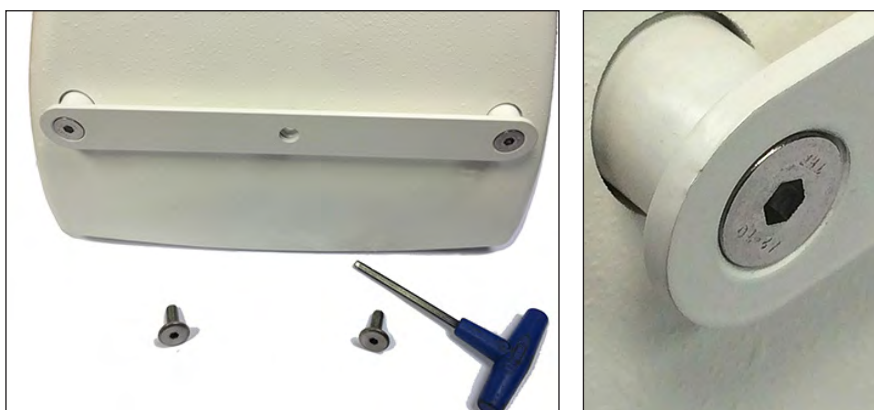

The cabinet assembly can now be attached to the yoke. If the yoke has already been fitted to a wall or ceiling as part of a permanent installation, this step should be undertaken by two people, for safety reasons: one to hold the cabinet in place and the other to fit the securing bolts at either end. If the cabinet is to be suspended from a scaff pole with a clamp, it may be possible to attach the yoke loop to the cabinet at ground level.

#### IMPORTANT INFORMATION

All standard safety protocols must be observed when working at height if the fixing point cannot be reached from the ground.

Note that the each end of the yoke arms has four 10.5 mm holes, 17.5 mm apart. Any pair of holes may be used; the choice will be determined only by the degree of vertical adjustment required and how close to the yoke frame the cabinet is preferred to be.



The M10 x 20 mm socket buttonhead screws (supplied with the yoke assembly) should first be threaded through the M10 shakeproof washer, then through the yoke fixing hole; then place a serrated washer on the bolt before screwing it into the captive nut in the centre of the side bars.

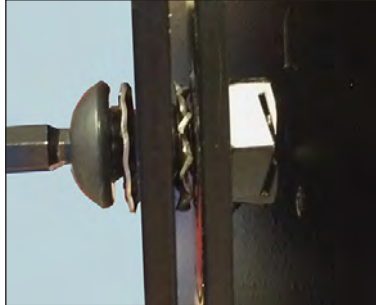

The bolt for the CDD15 is slightly different: this should first go through the M10 spring washer, then through the M10 plain washer, before going through the yoke, serrated washer and into the side bar.

If the cabinet is to be suspended from a scaf pole, fit the scaf clamp (or other single-point mounting) to the yoke using the 13 mm dia centre hole in the yoke main frame. Raise the cabinet to its mounting location and suspend it from the pole or grid; this is likely to require two people. Tighten the clamp bolt. Connect up and adjust pan and tilt angles as required.

#### IMPORTANT INFORMATION

All standard safety protocols must be observed when working at height.

Do not fully tighten the bolts at this stage, this should be done after the vertical position of the cabinet has been checked for the desired coverage.



Always fit a secondary safety retaining device. This should be a chain or steel rope attached directly to the cabinet, and NOT to the yoke. It can be attached to the cabinet by fitting an M8 eyebolt into one of the inserts provided for flying purposes. The other end should be attached to a securing point which is a permanent fixture in the building structure. The scaf pole itself may be suitable if it is a permanent fixture and not part of temporary rigging. If in any doubt, local Safety Regulations should be consulted and adhered to.

#### ALTERNATIVE POLE MOUNTING

Using a yoke assembly, a cabinet may be floor-mounted on a pole stand if wished. This is achieved by fitting a pole mount adaptor to the yoke instead of a scaf clamp. Before installing a CDD Series enclosure in this way, ensure that the floor stand used is rated for the weight of the cabinet.

## FLYING CDD SERIES CABINETS

A further installation option for the CDD10, CDD12 and CDD15 is to use standard flying techniques.

The CDD10, CDD12 and CDD15 can be flown by fitting M8 shouldered eye bolts to the cabinets and using steel rope or chains to suspend them at the desired height from suitable fixings in the roof. We recommend that you use Martin Audio eye bolts for this purpose (part number HTKCT05). All three models use the same eye bolts.



### IMPORTANT

Note that eye bolts for flying systems must be cast, shouldered fittings rated for the purpose. Forged steel eye bolts of the type typically available from DIY suppliers are NOT suitable and should not be used under any circumstances.

The M8 inserts in CDD cabinets are recessed and the shoulder on Martin Audio eye bolt fits into the recess. If you use another manufacturer's eye bolt that has a shoulder wider than the recess, you must space the bolt so it tightens down on the thread rather than the outer surface of the cabinet.

CDD cabinets can be flown in vertical ("portrait") or horizontal ("landscape") orientation.

Note that it is vital that the driver is orientated to suit the deployment used. "Out of the box" the driver is in the correct position for "portrait" use and must be rotated through 90° for "landscape" use. Please see page 13 for details of driver rotation.

There are a total of ten M8 inserts in each cabinet. With the cabinet in portrait, three of the M8 inserts are on the top, two on the bottom, two on each side and one on the back.

The most common method for suspending cabinets in portrait mode is to use the front two positions on the cabinet top as the primary suspension points with a third at the rear to provide any required downward tilt. The third position may be the rear insert on the cabinet top of the cabinet or the one on the back of the cabinet, if a steeper tilt is required.

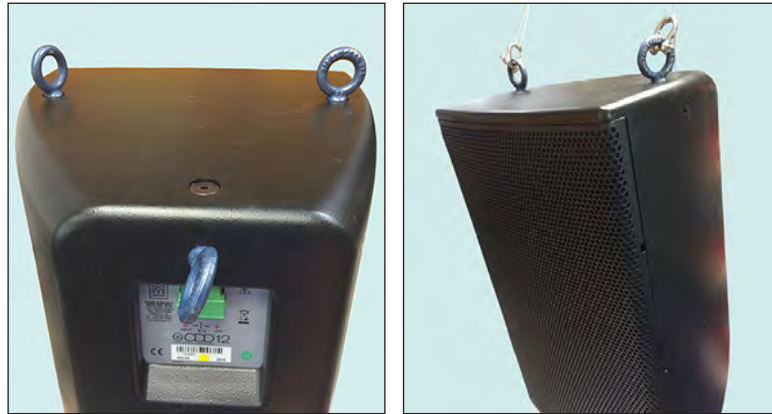

In horizontal mode, the third flying point (to adjust tilt) can be obtained by removing one of the six screws on the rear of the cabinet:

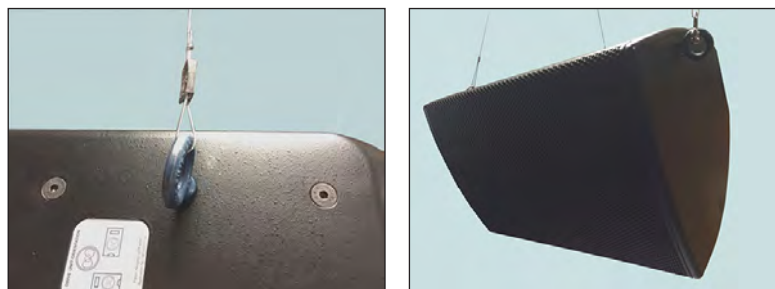

Always ensure that the rigging method and components used are suitable for both the weight of the cabinets and the suspension points at height.

## SX SERIES SUBWOOFERS - INSTALLATION

SX Subwoofers, having omnidirectional dispersion characteristics, will normally be floor-mounted in a suitable location in the room. As the bass frequencies involved are essentially non-directional, the location will be dictated simply by convenience and practicality. It is often only necessary to use a single subwoofer cabinet with a stereo system, as the active crossover will generate the mono LF feed required. See “System connections” on page 42 for more details regarding system connections.

Any model of SX subwoofer may be used in conjunction with any model from the CDD Series, provided the appropriate parameters are set up in the loudspeaker management system. However, practical combinations are likely to be as shown below:

|       | CDD5 | CDD6 | CDD8 | CDD10 | CDD12 | CDD18 |
|-------|------|------|------|-------|-------|-------|
| SX112 | •    | •    | •    | •     |       |       |
| SX212 | •    | •    | •    | •     | •     |       |
| SX118 |      |      |      | •     | •     | •     |
| SX218 |      |      |      |       | •     | •     |

### FLYING SX SUB-WOOFERS

SX Series subwoofers may also be flown; they are pre-fitted with threaded inserts to accept eye bolts.

Shouldered eye bolts are used in the inserts in the same manner as for CDD Series cabinets. Approved eye bolts are available from Martin Audio for the subwoofers: Part No. HTKCT06 – M10 eye bolt, suitable for all SX models.



#### IMPORTANT

Note that eye bolts for flying systems must be cast, shouldered fittings rated for the purpose. Forged steel eye bolts of the type typically available from DIY suppliers are NOT suitable and should not be used under any circumstances.



The M10 inserts in SX cabinets are recessed and the shoulder on Martin Audio eye bolts fits into the recess. If you use another manufacturer's eye bolt that has a shoulder wider than the recess, you will need to space the bolt so it tightens down on the thread rather than the outer surface of the cabinet.

Fit an eye bolt into each of the threaded inserts in the cabinet top (there are four, one in each corner).

Note that SX Series subwoofer cabinets are not designed to mate mechanically with CDD Series cabinets, and have no provision for doing so. If flying both CDD Series cabinets and SX Series subwoofers, they must be rigged independently of each other.

Use standard rigging techniques to raise the subwoofers to the required height. Always ensure that the rigging method and components used are suitable for both the weight of the cabinets and the suspension points at height.

## SYSTEM CONNECTIONS

All CDD Series and SX Series speakers are fitted with low-profile four-pin push-lock connectors, rated at 13 A (CDD5, CDD6 and CDD8) or 20 A (CDD10, CDD12, CDD15 and all SX models). These are mounted on the recessed rear panel, allowing for a very neat wiring job with no protruding connectors.

To permit simple interconnection between multiple speaker cabinets on the same circuit, two of the pins are designated as 'Link' connections; these can be used to "daisy-chain" the amplifier output to the next speaker:

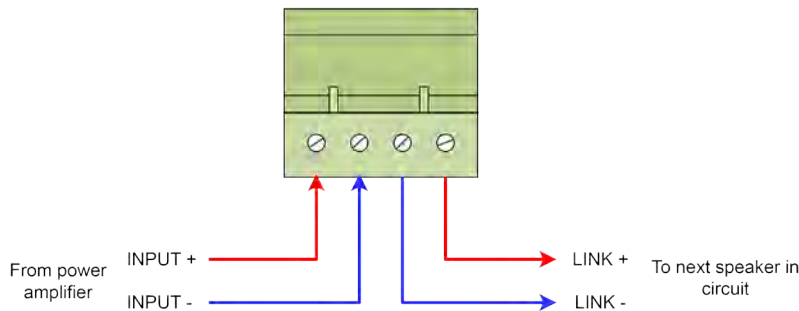

A mating connector is supplied with each cabinet. In a fixed installation, this can be fitted to the speaker cables during first fix.

### WR (WEATHERISED) MODELS ONLY

The connector block is protected by a weatherproof cover with an integral cable gland.

On Models CDD5TX-WR and CDD6TX-WR the gland is positioned for vertical cable entry; there is a second hole fitted with a "knock-out" to the right to allow a second gland (not supplied) to be fitted if cabinets are to be daisy-chained. On Models CDD8-WR and above, a single cable gland is positioned for rearwards cable entry.



CDD5/6TX-WR



CDD8-WR and above

The cover is retained in place by two (CDD8-WR and above) or three (CDD5/6TX-WR) hex-head screws: remove these to remove the cover, taking care not to damage the gasket which seals the cover against the rear panel. Loosen the gland's cable clamp nut and pass the cable through the gland assembly and then connect to the INPUT terminals as described above. In the case of the CDD5TX-WR or CDD6TX-WR, if daisy-chaining to another speaker, remove the knock-out, fit a second gland and repeat the process, connecting the second cable to the LINK terminals.

**NOTE:** To maintain the enclosure's IP rating, the second gland must be of the same type as the pre-fitted one and of the correct size for the hole.

**IMPEDANCES**

All CDD Series loudspeakers have an impedance of 8 ohms. (Models CDD5 and CDD6 only - see section below regarding 70/100 V-line operation.)

Subwoofer Models SX112 and SX118 have an impedance of 8 ohms

Subwoofer Models SX212 and SX218 have an impedance of 4 ohms.

**70/100 V-LINE OPERATION (MODELS CDD5TX-WR AND CDD6TX-WR ONLY)**

Models CDD5 and CDD6 are also available as variants CDD5TX-WR and CDD6TX-WR respectively, with a 70/100 V-line transformer fitted internally. In accordance with normal line system practice, a rotary switch is provided to select the required power rating. An additional switch position selects low-impedance operation (8 ohms).

The rotary switch is located on the front of the cabinet, so the grille needs to be removed to access it. This has the advantage of allowing the power setting to be adjusted once the speaker has been installed and correctly positioned.

|          | CDD5TX-WR                        |            | CDD6TX-WR |            |
|----------|----------------------------------|------------|-----------|------------|
|          |                                  |            |           |            |
| SW POSN. | 70 V-line                        | 100 V-line | 70 V-line | 100 V-line |
| 1        | Low-impedance operation (8 ohms) |            |           |            |
| 2        | 3 W                              | 6 W        | 6.5 W     | 12.5 W     |
| 3        | 6 W                              | 12.5 W     | 12.5 W    | 25 W       |
| 4        | 12.5 W                           | 25 W       | 25 W      | 50 W       |
| 5        | 25 W                             | n/a        | 50 W      | n/a        |

High levels of low-frequency signals can cause transformer core saturation, which can cause distortion and sounds unpleasant. If driving 70/100 V-line loudspeakers with bass-heavy programme material at high levels, we strongly recommend that a high-pass filter is included in the signal path. This can be easily implemented by the DX0.5 loudspeaker management system; many industrial power amplifiers designed for 70/100 V-line operation will have selectable fixed filters for this purpose. If such filters are not available in the amplifiers, they can be implemented in the Loudspeaker Management System controller.

**Cable specifications**

Use good-quality, fine-stranded two-core speaker cable. Depending on the type of installation and the system’s application, local regulations may dictate the type of cable jacket to be installed (e.g., low-smoke hazard).

The minimum gauge of cable to be used is determined by the length of cable run:

- Up to 30 m run – use minimum 2.5 mm<sup>2</sup> cable
- Over 30 m run – use minimum 4.0 mm<sup>2</sup> cable

**SYSTEM EXAMPLES**

The following diagrams show examples of possible systems. All assume the use of the DX0.5 loudspeaker management system. This is recommended for all systems, even when no subwoofers are in use, as when set correctly to suit the amplifiers being used, the limiter functions provide excellent loudspeaker protection against overloads and possible amplifier faults.

**1 x Stereo**

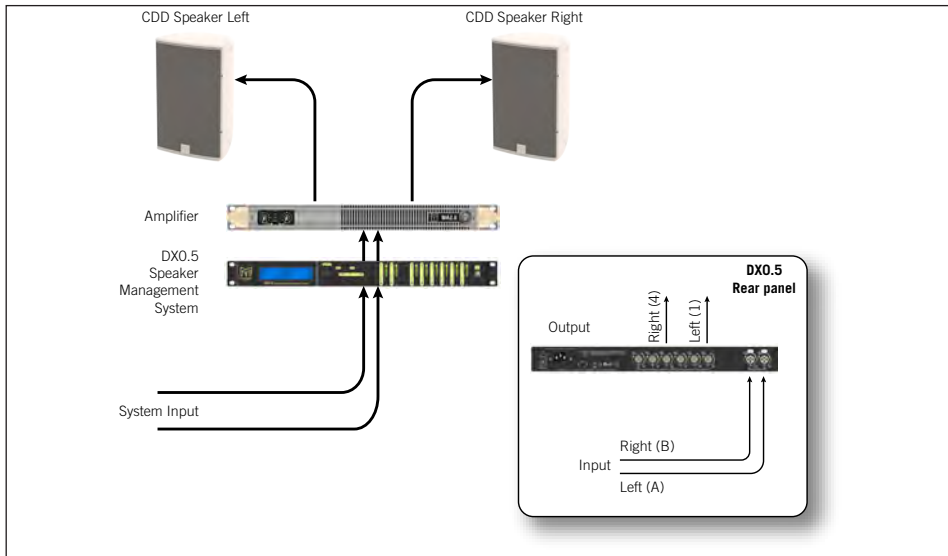

**2 x Stereo + 1 Sub**

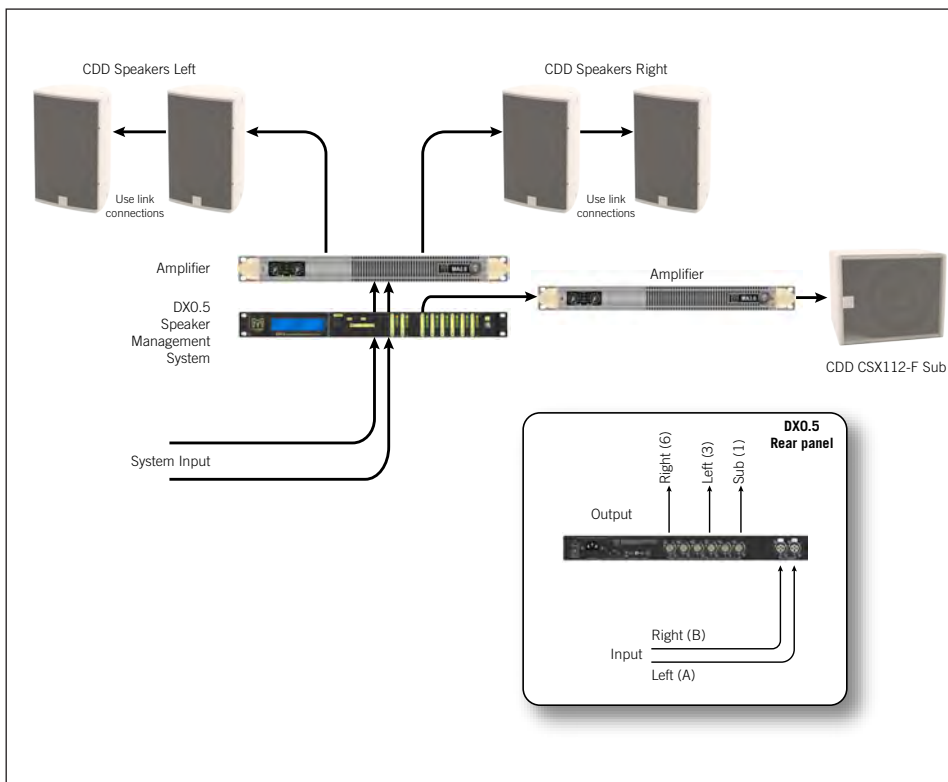



### 3 x Stereo + 2 Sub

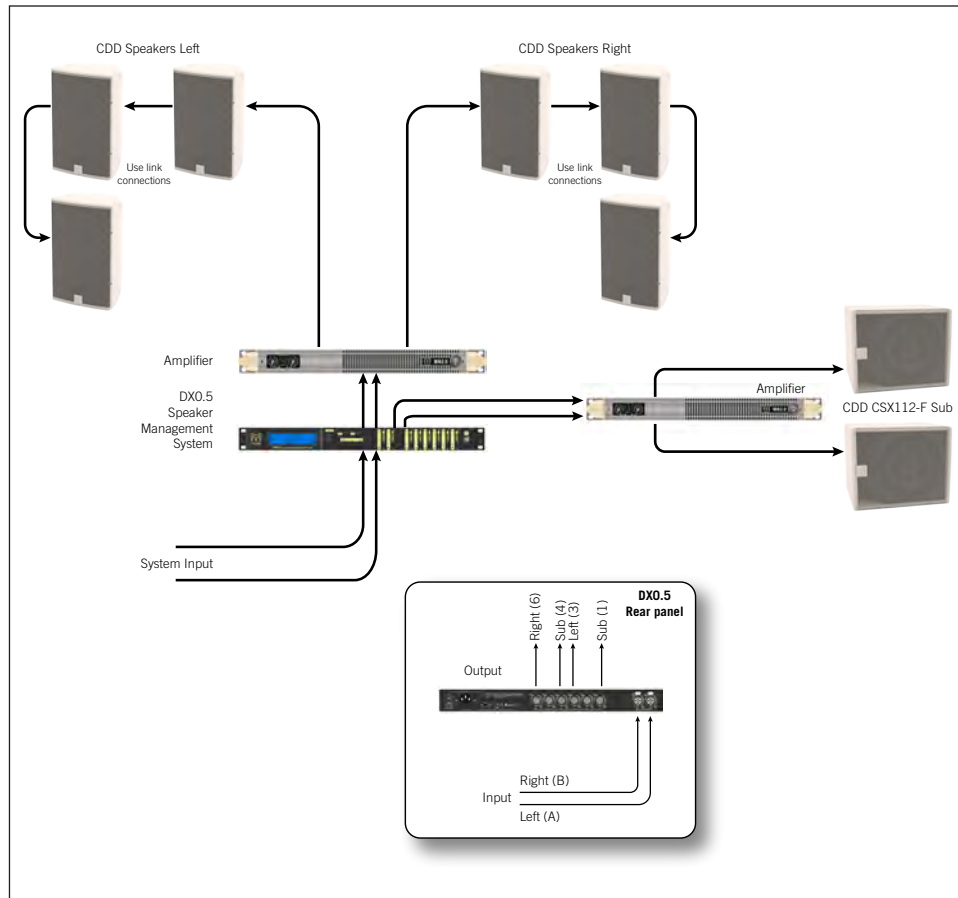

## MARTIN AUDIO DX0.5 LOUDSPEAKER MANAGEMENT SYSTEM



The DX0.5 is a professional two-input, six-output DSP-based loudspeaker management system in a 1U rackmounting unit, which has been developed specifically for use with the CDD range.

The DX0.5 is ideal for use as the stereo crossover in systems incorporating SX subwoofers. As well as its crossover functions, it includes five parametric/shelving filters on each input and seven filters on each output. Level control, muting and delay are available on all inputs and outputs, plus dedicated HF/LF filters and protective limiting are also provided on all outputs.

The DX0.5 is supplied with all CDD parameters built in. Additional presets for other Martin Audio products can be downloaded from the website. There are 24 memory locations in the unit suitable for storing presets for each CDD model. Martin Audio strongly recommends using the DX0.5, but settings for use with other controllers are tabulated on the following page, “Using alternative controllers”- user entry of parameters is required.

The full DX0.5 User Guide is available on-line at [www.martin-audio.com](http://www.martin-audio.com), and includes numerous examples of system wiring.

### CDD PRESET LIST

| PRESET No. | NAME                  | OUTPUT   |          |         |          |          |         |
|------------|-----------------------|----------|----------|---------|----------|----------|---------|
|            |                       | 1        | 2        | 3       | 4        | 5        | 6       |
| 1          | CDD5                  | CDD5 L   | CDD5 L   | CDD5 L  | CDD5 R   | CDD5 R   | CDD5 R  |
| 2          | CDD6                  | CDD6 L   | CDD6 L   | CDD6 L  | CDD6 R   | CDD6 R   | CDD6 R  |
| 3          | CDD8                  | CDD8 L   | CDD8 L   | CDD8 L  | CDD8 R   | CDD8 R   | CDD8 R  |
| 4          | CDD10                 | CDD10 L  | CDD10 L  | CDD10 L | CDD10 R  | CDD10 R  | CDD10 R |
| 5          | CDD12                 | CDD12 L  | CDD12 L  | CDD12 L | CDD12 R  | CDD12 R  | CDD12 R |
| 6          | CDD15                 | CDD15 L  | CDD15 L  | CDD15 L | CDD15 R  | CDD15 R  | CDD15 R |
| 7          | CSX112-F, 212-F CDD5  | CSX112 L | CSX212 L | CDD5 L  | CSX112 R | CSX212 R | CDD5 R  |
| 8          | CSX112-F, 212-F CDD6  | CSX112 L | CSX212 L | CDD6 L  | CSX112 R | CSX212 R | CDD6 R  |
| 9          | CSX112-F, 212-F CDD8  | CSX112 L | CSX212 L | CDD8 L  | CSX112 R | CSX212 R | CDD8 R  |
| 10         | CSX112-F, 212-F CDD10 | CSX112 L | CSX212 L | CDD10 L | CSX112 R | CSX212 R | CDD10 R |
| 11         | CSX118-F, 218-F CDD10 | CSX118 L | CSX218 L | CDD10 L | CSX118 R | CSX218 R | CDD10 R |
| 12         | CSX112-F, 212-F CDD12 | CSX118 L | CSX218 L | CDD12 L | CSX118 R | CSX218 R | CDD12 R |
| 13         | CSX112-F, 212-F CDD15 | CSX118 L | CSX218 L | CDD15 L | CSX118 R | CSX218 R | CDD15 R |

## USING ALTERNATIVE CONTROLLERS

Alternative high quality loudspeaker management systems may be used. The table below lists the parameters for each CDD Series speaker that need to be entered into the controller for safe and optimised operation. Please note that the data provided is based on the algorithms used by Martin Audio DX Series Loudspeaker Management Systems; third-party systems are likely to use different algorithms which may result in both sub-optimal performance and reduce loudspeaker protection.

|                    | Gain <sup>1</sup> | Filters               |                       | EQ      |     |         | Limiter threshold <sup>3</sup> |
|--------------------|-------------------|-----------------------|-----------------------|---------|-----|---------|--------------------------------|
|                    |                   | HPF Freq <sup>2</sup> | LPF Freq <sup>2</sup> | Freq    | Q   | Gain    |                                |
| CDD5               | 0 dB              | 60 Hz                 | >32 kHz               | 101 Hz  | 1.5 | +4 dB   | -2 dBu                         |
| CDD5+ CSX112/212-F | 7.5 dB            | 110 Hz                | >32 kHz               | 101 Hz  | 1.5 | +4 dB   |                                |
| CDD6               | 0 dB              | 50 Hz                 | >32 kHz               | 75 Hz   | 1.2 | +6 dB   | -1 dBu                         |
| CDD6+CSX112/212-F  | 6 dB              | 100 Hz                | >32 kHz               | 75 Hz   | 1.2 | +6 dB   |                                |
| CDD8               | 0 dB              | 40 Hz                 | >32 kHz               | 72 Hz   | 1.2 | +6 dB   | +1 dBu                         |
| CDD8+CSX112/212-F  | 5 dB              | 100 Hz                | >32 kHz               | 72 Hz   | 1.2 | +6 dB   |                                |
| CDD10              | 0 dB              | 40 Hz                 | >32 kHz               | 70.2 Hz | 1.3 | +6 dB   | +3 dBu                         |
| CDD10+CSX112/212-F | 3 dB              | 80 Hz                 | >32 kHz               | 70.2 Hz | 1.3 | +6 dB   |                                |
| CDD10+CSX118/218-F | 2 dB              | 80 Hz                 | >32 kHz               | 70.2 Hz | 1.3 | +6 dB   |                                |
| CDD12              | 0 dB              | 20 Hz                 | >32 kHz               | 70.2 Hz | 0.9 | +6 dB   | +4 dBu                         |
| CDD12+CSX118/218-F | 0 dB              | 80 Hz                 | >32 kHz               | 70.2 Hz | 0.9 | +6 dB   |                                |
| CDD15              | 0 dB              | 20 Hz                 | >32 kHz               | 66 Hz   | 0.9 | +6.5 dB | +5 dBu                         |
| CDD15+CSX118/218-F | -2 dB             | 80 Hz                 | >32 kHz               | 66 Hz   | 0.9 | +6.5 dB |                                |
| CSX112-F+CDD5      | 6 dB              | 20 Hz                 | 120 Hz                | 55 Hz   | 1.0 | +6 dB   | +5 dBu                         |
| CSX112-F+CDD6/8    | 6 dB              | 20 Hz                 | 110 Hz                | 55 Hz   | 1.0 | +6 dB   |                                |
| CSX112-F+CDD10     | 6 dB              | 20 Hz                 | 90 Hz                 | 55 Hz   | 1.0 | +6 dB   |                                |
| CSX212-F+CDD5      | 0 dB              | 20 Hz                 | 120 Hz                | 55 Hz   | 1.0 | +6 dB   | +5 dBu                         |
| CSX212-F+CDD6/8    | 0 dB              | 20 Hz                 | 110 Hz                | 55 Hz   | 1.7 | +6 dB   |                                |
| CSX212-F+CDD10     | 0 dB              | 20 Hz                 | 90 Hz                 | 55 Hz   | 1.0 | +6 dB   |                                |
| CSX118-F           | 6 dB              | 20Hz                  | 90 Hz                 |         | 0.0 |         | +8 dBu                         |
| CSX218-F           | 0 dB              | 20 Hz                 | 90 Hz                 | 40 Hz   | 2.0 | +4 dB   | +8 dBu                         |

<sup>1</sup> For all models: phase=in; delay=0 ms

<sup>2</sup> For all models: filter type 24 dB/oct LR

<sup>3</sup> The figures in this column are based on an amplifier gain of 32 dB. For amplifiers with different gains, please refer to the loudspeaker data spreadsheet on our website, which will calculate the correct threshold setting for any given gain.

## AMPLIFIERS – RECOMMENDATIONS

Martin Audio MA Series two channel power amplifiers are recommended for use with CDD Series loudspeakers and SX Series subwoofers. These amplifiers work well down to 2 ohms, making it possible to power up to four cabinets in parallel from each channel. Models are available with power ratings from 700 W/ch to 4000 W/ch (into 4 ohms).

Other manufacturers' power amplifiers may be used provided they are capable of delivering the necessary power into the combined impedance of the cabinets in use. Note that many amplifiers suffer sonic degradation when driving low load impedances or, worse still, shut down. Always check your intended power amplifier's specifications and conduct listening tests before committing to a very low impedance system design.

The table below specifies the recommended minimum amplifier rating for each model of CDD Series and SX Series cabinet. The "Recommended models" column lists the Martin Audio MA Series amplifier models suitable for each speaker model.

| Model | Rating, AES | Rating, Peak | Impedance | Minimum amplifier  | Recommended models |
|-------|-------------|--------------|-----------|--------------------|--------------------|
| CDD5  | 100 W       | 400 W        | 8 ohms    | 800 W into 4 ohms  | MA2.8Q, MA2.0      |
| CDD6  | 150 W       | 600 W        | 8 ohms    | 1200 W into 4 ohms | MA2.8Q, MA2.0      |
| CDD8  | 200 W       | 800 W        | 8 ohms    | 1600 W into 4 ohms | MA2.8Q, MA2.0      |
| CDD10 | 250 W       | 1000 W       | 8 ohms    | 2000 W into 4 ohms | MA2.0              |
| CDD12 | 300 W       | 1200 W       | 8 ohms    | 2400 W into 4 ohms | MA2.0, MA3.0       |
| CDD15 | 400 W       | 1600 W       | 8 ohms    | 2400 W into 4 ohms | MA3.0, MA5.2K      |
| SX112 | 400 W       | 1600 W       | 8 ohms    | 3200 W into 4 ohms | MA3.0, MA5.2K      |
| SX212 | 800 W       | 3200 W       | 4 ohms    | 3200 W into 4 ohms | MA5.2K             |
| SX118 | 1000 W      | 4000 W       | 8 ohms    | 8000 W into 4 ohms | MA5.2K             |
| SX218 | 2000 W      | 8000 W       | 4 ohms    | 8000 W into 4 ohms | MA9.6K, MA12K      |

## APPENDIX

### SPECIFICATIONS

#### CDD5, CDD6, CDD8

|                                 | CDD5   | CDD6   | CDD8   |
|---------------------------------|--|--|--|
| TYPE                            | Ultra-compact, Coaxial Differential Dispersion passive two-way system  | Ultra-compact, Coaxial Differential Dispersion passive two-way system  | Ultra-compact, Coaxial Differential Dispersion passive two-way system  |
| FREQUENCY RESPONSE <sup>1</sup> | 100 Hz-20 kHz $\pm$ 3 dB,<br>-10 dB @ 70Hz   | 80 Hz-20 kHz $\pm$ 3 dB,<br>-10 dB @ 70 Hz   | 70 Hz-20 kHz $\pm$ 3 dB,<br>-10 dB @ 55 Hz   |
| DRIVER                          | LF: 5.25" (130 mm)/1.25" (32 mm) voice coil, long excursion, ferrite motor system<br>HF: 0.75" (19 mm) voice coil, fabric dome with neodymium motor system   | LF: 6.5" (165 mm)/1.5" (38 mm) voice coil, long excursion, ferrite motor system<br>HF: 1" (25 mm) voice coil, fabric dome with neodymium motor system  | LF: 8" (200 mm)/2" (50 mm) voice coil, long excursion, shared ferrite motor system with HF<br>HF: 1" (25 mm) exit/1.4" (38 mm) voice coil, polyimide dome compression driver   |
| RATED POWER <sup>2</sup>        | 100 W AES, 400 W peak  | 150 W AES, 600 W peak  | 200 W AES, 800 W peak  |
| RECOMMENDED AMPLIFIER           | MA2.8Q, MA2.0  | MA2.8Q, MA2.0  | MA2.8Q, MA2.0  |
| SENSITIVITY <sup>3</sup>        | 90 dB  | 91 dB  | 94 dB  |
| MAXIMUM SPL <sup>4</sup>        | 110 dB continuous, 116 dB peak   | 113 dB continuous, 119 dB peak   | 117 dB continuous, 123 dB peak   |
| NOMINAL IMPEDANCE               | 8 ohms   | 8 ohms   | 8 ohms   |
| DISPERSION (-6 dB) <sup>5</sup> | 120°-90° horizontal, 80° vertical (user-rotatable)   | 110°-80° horizontal, 80° vertical (user-rotatable)   | 110°-80° horizontal, 60° vertical (user-rotatable)   |
| CROSSOVER                       | 2.5 kHz passive  | 2.5 kHz passive  | 2.3 kHz passive  |
| ENCLOSURE                       | 3 litre, ABS   | 9 litre, composite material  | 14 litre, composite material   |
| FINISH                          | Black or white   | Black or white textured paint  | Black or white textured paint  |
| PROTECTIVE GRILLE               | Standard models only: black or white perforated steel with scrim cloth backing<br>"WR" models only: black or white perforated, zinc-plated steel with scrim cloth backing, Declon® synthetic fabric layer and inner, zinc-plated, hydrophobic steel mesh layer | Standard models only: black or white perforated steel with scrim cloth backing<br>"WR" models only: black or white perforated, zinc-plated steel with scrim cloth backing, Declon® synthetic fabric layer and inner, zinc-plated, hydrophobic steel mesh layer | Standard models only: black or white perforated steel with scrim cloth backing<br>"WR" models only: black or white perforated, zinc-plated steel with scrim cloth backing, Declon® synthetic fabric layer and inner, zinc-plated, hydrophobic steel mesh layer |
| CONNECTORS                      | Low-profile 13 A push-lock<br>WR models only: weatherproof cover with gasket seal and cable gland  | Low-profile 13 A push-lock<br>WR models only: weatherproof cover with gasket seal and cable gland  | Low-profile 13 A push-lock<br>WR models only: weatherproof cover with gasket seal and cable gland  |
| PIN CONNECTIONS                 | Left to right: Input+, Input -, Link -, Link +   | Left to right: Input+, Input -, Link -, Link +   | Left to right: Input+, Input -, Link -, Link +   |
| FITTINGS                        | 6 x M5 inserts for wall/ceiling brackets   | 4 x M6 inserts for wall/ceiling brackets   | 6 x M6 inserts for wall/ceiling brackets   |
| ENVIRONMENTAL                   | IP54 (Model CDD5TX-WR only)  | IP54 (Model CDD6TX-WR only)  | IP54 (Model CDD8-WR only)  |
| DIMENSIONS                      | (W) 160 mm x (H) 230 mm x (D) 149 mm<br>(W) 6.3 in x (H) 9.1 in x (D) 5.9 in   | (W) 210 mm x (H) 325 mm x (D) 210 mm<br>(W) 8.3 in x (H) 12.8 in x (D) 8.3 in  | (W) 256 mm x (H) 410 mm x (D) 253 mm<br>(W) 10.1 in x (H) 16.1 in x (D) 10 in  |
| WEIGHT                          | 2.7 kg (6 lb)  | 5 kg (11 lb)   | 9.5 kg (21 lb)   |
| ACCESSORIES                     | Wall bracket supplied (replacement part white ASM10001 or black ASM1002)<br>CDDCB5B ceiling bracket black<br>CDDCB5W ceiling bracket white   | WB6/8B wall bracket black<br>WB6/8W wall bracket white<br>CDDCB6/8B ceiling bracket black<br>CDDCB6/8W ceiling bracket white   | WB6/8B wall bracket black<br>WB6/8W wall bracket white<br>CDDCB6/8B ceiling bracket black<br>CDDCB6/8W ceiling bracket white   |

#### Notes

- (1) Measured on-axis in open (4 pi) space at 2 metres, then referred to 1 metre.
- (2) AES Standard ANSI S4.26-1984.
- (3) Measured in open (4 pi) space at 2 metres with 2.83 V input, using band limited pink noise, then referred to 1 metre.
- (4) Calculated at 1 m.
- (5) Measured in open (4 pi) space at 2 metres.

## CDD10, CDD12, CDD15

|                                 | CDD10  | CDD12  | CDD15  |
|---------------------------------|--|--|--|
| TYPE                            | Compact, Coaxial Differential Dispersion passive two-way system  | Compact, high-output, Coaxial Differential Dispersion passive two-way system   | High-output, Coaxial Differential Dispersion passive two-way system  |
| FREQUENCY RESPONSE <sup>1</sup> | 65 Hz-20 kHz $\pm$ 3 dB,<br>-10 dB @ 55 Hz   | 62 Hz-20 kHz $\pm$ 3 dB,<br>-10 dB @ 50 Hz   | 55 Hz-18 kHz $\pm$ 3 dB,<br>-10 dB @ 45 Hz   |
| DRIVER                          | LF: 10" (250 mm)/2.5" (63.5 mm) voice coil, long excursion, shared ferrite motor system with HF<br><br>HF: 1" (25 mm) exit/1.4" (38 mm) voice coil, polyimide dome compression driver  | LF: 12" (300 mm)/2.5" (63.5 mm) voice coil, long excursion, shared ferrite motor system with HF<br><br>HF: 1" (25 mm) exit/1.7" (44 mm) voice coil, polyimide dome compression driver  | LF: 15" (380 mm)/3" (75 mm) voice coil, long excursion, shared ferrite motor system with HF<br><br>HF: 1.4" (32 mm) exit/3" (75 mm) voice coil, titanium dome compression driver   |
| RATED POWER <sup>2</sup>        | 250 W AES, 1000 W peak   | 300 W AES, 1200 W peak   | 400 W AES, 1600 W peak   |
| RECOMMENDED AMPLIFIER           | MA2.0  | MA2.0, MA3.0   | MA3.0, MA5.2K  |
| SENSITIVITY <sup>3</sup>        | 96 dB  | 97 dB  | 100 dB   |
| MAXIMUM SPL <sup>4</sup>        | 120 dB continuous, 126 dB peak   | 122 dB continuous, 128 dB peak   | 126 dB continuous, 132 dB peak   |
| NOMINAL IMPEDANCE               | 8 ohms   | 8 ohms   | 8 ohms   |
| DISPERSION (-6 dB) <sup>5</sup> | 110°-75° horizontal, 60° vertical (user-rotatable)   | 110°-60° horizontal, 60° vertical (user-rotatable)   | 100°-60° horizontal, 60° vertical (user-rotatable)   |
| CROSSOVER                       | 2 kHz passive  | 1.9 kHz passive  | 1.6 kHz passive  |
| ENCLOSURE                       | 28 litre, composite material   | 38 litre, composite material   | 68 litre, composite material   |
| FINISH                          | Black or white textured paint  | Black or white textured paint  | Black or white textured paint  |
| PROTECTIVE GRILLE               | Standard models only: black or white perforated steel with scrim cloth backing<br><br>"WR" models only: black or white perforated, zinc-plated steel with scrim cloth backing, Declon® synthetic fabric layer and inner, zinc-plated, hydrophobic steel mesh layer | Standard models only: black or white perforated steel with scrim cloth backing<br><br>"WR" models only: black or white perforated, zinc-plated steel with scrim cloth backing, Declon® synthetic fabric layer and inner, zinc-plated, hydrophobic steel mesh layer | Standard models only: black or white perforated steel with scrim cloth backing<br><br>"WR" models only: black or white perforated, zinc-plated steel with scrim cloth backing, Declon® synthetic fabric layer and inner, zinc-plated, hydrophobic steel mesh layer |
| CONNECTORS                      | Low-profile 20 A push-lock<br><br>WR models only: weatherproof cover with gasket seal and cable gland  | Low-profile 20 A push-lock<br><br>WR models only: weatherproof cover with gasket seal and cable gland  | Low-profile 20 A push-lock<br><br>WR models only: weatherproof cover with gasket seal and cable gland  |
| PIN CONNECTIONS                 | Left to right: Input+, Input -, Link -, Link+  | Left to right: Input+, Input -, Link -, Link+  | Left to right: Input+, Input -, Link -, Link+  |
| FITTINGS                        | 6 x M8 inserts for wall bracket<br><br>10 x M8 fly points  | 6 x M8 inserts for wall bracket<br><br>10 x M8 fly points  | 6 x M8 inserts for wall bracket<br><br>10 x M8 fly points  |
| ENVIRONMENTAL                   | IP54 (Model CDD10-WR only)   | IP54 (Model CDD12-WR only)   | IP54 (Model CDD15-WR only)   |
| DIMENSIONS                      | (W) 323 mm x (H) 515 mm x (D) 311 mm<br>(W) 12.7 in x (H) 20.3 in x (D) 12.2 in  | (W) 357 mm x (H) 571 mm x (D) 348 mm<br>(W) 14.1 in x (H) 22.5 in x (D) 13.7 in  | (W) 425 mm x (H) 691 mm x (D) 411 mm<br>(W) 16.7 in x (H) 27.2 in x (D) 16.2 in  |
| WEIGHT                          | 15.3 kg (33.7 lb)  | 19.3 kg (42.5 lb)  | 27.7 kg (61 lb)  |
| ACCESSORIES                     | WB10/12B wall bracket black<br>WB10/12W wall bracket white<br>CDDYA10B yoke assembly black<br>CDDYA10W yoke assembly white   | WB10/12B wall bracket black<br>WB10/12W wall bracket white<br>CDDYA12B yoke assembly black<br>CDDYA12W yoke assembly white   | WB15B wall bracket black<br>WB15W wall bracket white<br>CDDYA15B yoke assembly black<br>CDDYA15W yoke assembly white   |

## Notes

- (1) Measured on-axis in open (4 pi) space at 2 metres, then referred to 1 metre.
- (2) AES Standard ANSI S4.26-1984.
- (3) Measured in open (4 pi) space at 2 metres with 2.83 V input, using band limited pink noise, then referred to 1 metre.
- (4) Calculated at 1 m.
- (5) Measured in open (4 pi) space at 2 metres.

## SX112, SX212

|                                 | SX112   | SX212   |
|---------------------------------|---|---|
| TYPE                            | Compact, single driver, direct radiating subwoofer  | Compact, dual-driver, direct radiating subwoofer  |
| FREQUENCY RESPONSE <sup>1</sup> | 48 Hz-150 Hz $\pm$ 3 dB, -10 dB @ 35 Hz   | 48 Hz-150 Hz $\pm$ 3 dB, -10 dB @ 35 Hz   |
| DRIVER                          | 12" (300 mm)/3" (75 mm) voice coil, long excursion, ferrite magnet, waterproof cone               | 2 x 12" (300 mm)/3" (75 mm) voice coil, long excursion, ferrite magnet, waterproof cone           |
| RATED POWER <sup>2</sup>        | 400 W AES, 1600 W peak  | 800 W AES, 3200 W peak  |
| RECOMMENDED AMPLIFIER           | MA3.0   | MA5.2K  |
| SENSITIVITY <sup>3</sup>        | 102 dB  | 105 dB  |
| MAXIMUM SPL <sup>4</sup>        | 128 dB continuous, 134 dB peak  | 134 dB continuous, 140 dB peak  |
| NOMINAL IMPEDANCE               | 8 ohms  | 4 ohms  |
| DISPERSION (-6 dB)              | Omnidirectional   | Omnidirectional   |
| CROSSOVER                       | 80–120 Hz, via DX0.5 or DX2 controller  | 80–120 Hz, via DX0.5 or DX2 controller  |
| ENCLOSURE                       | 52 litre, high-density MDF  | 100 litre, high-density MDF   |
| FINISH                          | Black or white textured paint   | Black or white textured paint   |
| PROTECTIVE GRILLE               | Black or white perforated steel   | Black or white perforated steel   |
| CONNECTORS                      | Low-profile 20 A push-lock<br>WR models only: weatherproof cover with gasket seal and cable gland | Low-profile 20 A push-lock<br>WR models only: weatherproof cover with gasket seal and cable gland |
| PIN CONNECTIONS                 | Left to right: Input+, Input -, Link -, Link+   | Left to right: Input+, Input -, Link -, Link+   |
| ENVIRONMENTAL                   | IP24 (Model CSX112-FWR only)  | IP24 (Model CSX212-FWR only)  |
| DIMENSIONS                      | (W) 487 mm x (H) 385 mm x (D) 410 mm<br>(W) 19.2 in x (H) 15.2 in x (D) 16.1 in                   | (W) 872 mm x (H) 385 mm x (D) 437 mm<br>(W) 34.3 in x (H) 15.2 in x (D) 17.2 in                   |
| WEIGHT                          | 21.5 kg (47.3 lb)   | 39 kg (86 lb)   |

### Notes

- (1) Measured on-axis in half space at 2 metres, then referred to 1 metre.
- (2) AES Standard ANSI S4.26-1984.
- (3) Measured in half space at 2 metres with 2.83 V input, using band limited pink noise, then referred to 1 metre.
- (4) Calculated in half space at 1 metre.

## SX118, SX218

|                                 | SX118   | SX218   |
|---------------------------------|---|---|
| TYPE                            | Compact, direct radiating subwoofer   | Dual-driver, direct radiating subwoofer   |
| FREQUENCY RESPONSE <sup>1</sup> | 40 Hz-150 Hz $\pm$ 3 dB, -10 dB @ 35 Hz   | 35 Hz-150 Hz $\pm$ 3 dB, -10 dB @ 30 Hz   |
| DRIVER                          | 18" (460 mm)/4" (100 mm) voice coil, long excursion, ferrite magnet, waterproof cone              | 2 x 18" (460 mm)/4" (100 mm) voice coil, long excursion, ferrite magnet, waterproof cone                            |
| RATED POWER <sup>2</sup>        | 1000 W AES, 4000 W peak   | 2000 W AES, 8000 W peak   |
| RECOMMENDED AMPLIFIER           | MA5.2K  | MA9.6K, MA12K   |
| SENSITIVITY <sup>3</sup>        | 102 dB  | 105 dB  |
| MAXIMUM SPL <sup>4</sup>        | 132 dB continuous, 138 dB peak  | 138 dB continuous, 144 dB peak  |
| NOMINAL IMPEDANCE               | 8 ohms  | 4 ohms  |
| DISPERSION (-6 dB)              | Omnidirectional   | Omnidirectional   |
| CROSSOVER                       | 80–120 Hz, via DX0.5 or DX2 controller  | 80–120 Hz, via DX0.5 or DX2 controller  |
| ENCLOSURE                       | 160 litre, high-density MDF   | 330 litre high-density MDF  |
| FINISH                          | Black or white textured paint   | Black or white textured paint   |
| PROTECTIVE GRILLE               | Black or white perforated steel   | Black or white perforated steel   |
| CONNECTORS                      | Low-profile 20 A push-lock<br>WR models only: weatherproof cover with gasket seal and cable gland | Low-profile 20 A push-lock<br>WR models only: weatherproof cover with gasket seal and cable gland                   |
| PIN CONNECTIONS                 | Left to right: Input+, Input -, Link -, Link+   | Left to right: Input+, Input -, Link -, Link+   |
| FITTINGS                        |   | Four pocket handles   |
| ENVIRONMENTAL                   | IP24 (Model CSX118F-WR only)  | IP24 (Model CSX218F-WR only)  |
| DIMENSIONS                      | (W) 530 mm x (H) 662 mm x (D) 640 mm<br>(W) 20.9 in x (H) 26.1 in x (D) 25.2 in                   | (W) 1085 mm x (H) 530 mm x (D) 780 mm*<br>(W) 42.7 in x (H) 20.9 in x (D) 30.7 in*<br>*905 mm (35.6 in) with wheels |
| WEIGHT                          | 42 kg (93 lb)   | 84 kg (185 lb)  |

## Notes

- (1) Measured on-axis in half space at 2 metres, then referred to 1 metre.
- (2) AES Standard ANSI S4.26-1984.
- (3) Measured in half space at 2 metres with 2.83 V input, using band limited pink noise, then referred to 1 metre.
- (4) Calculated in half space at 1 metre.



**TECHNICAL DRAWINGS**

The drawings on the following pages show the standard models. The Weatherised versions have the same dimensions but the appearance of the rear panel differs slightly due to the additional weatherproof cover over the connector panel.

**CDD5**

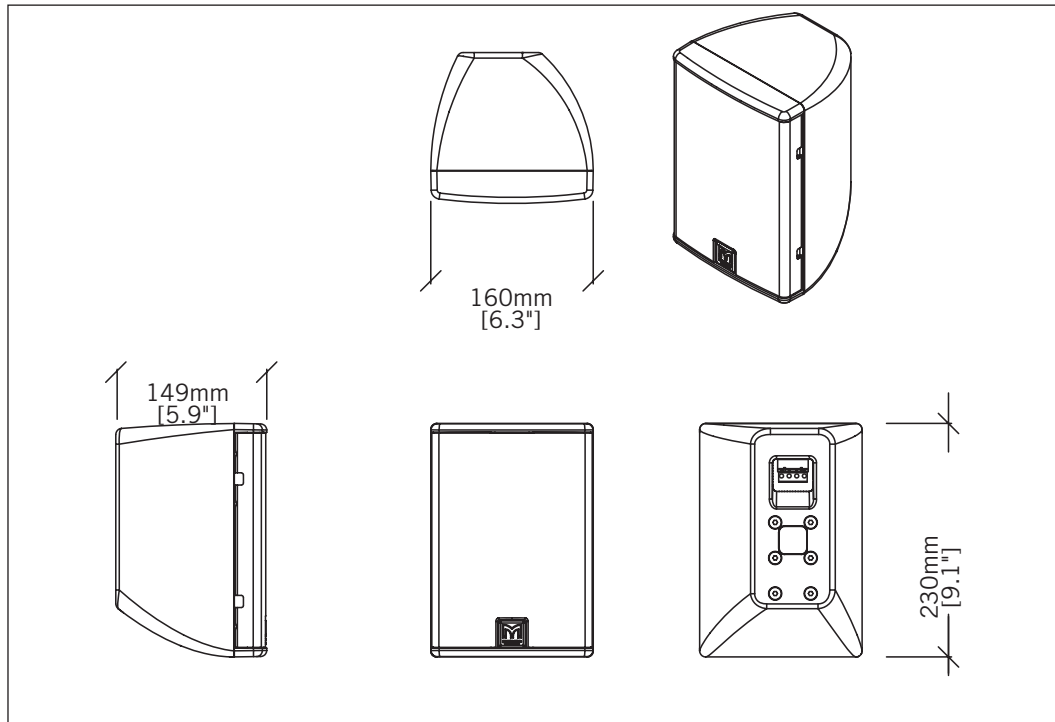

**CDD6**

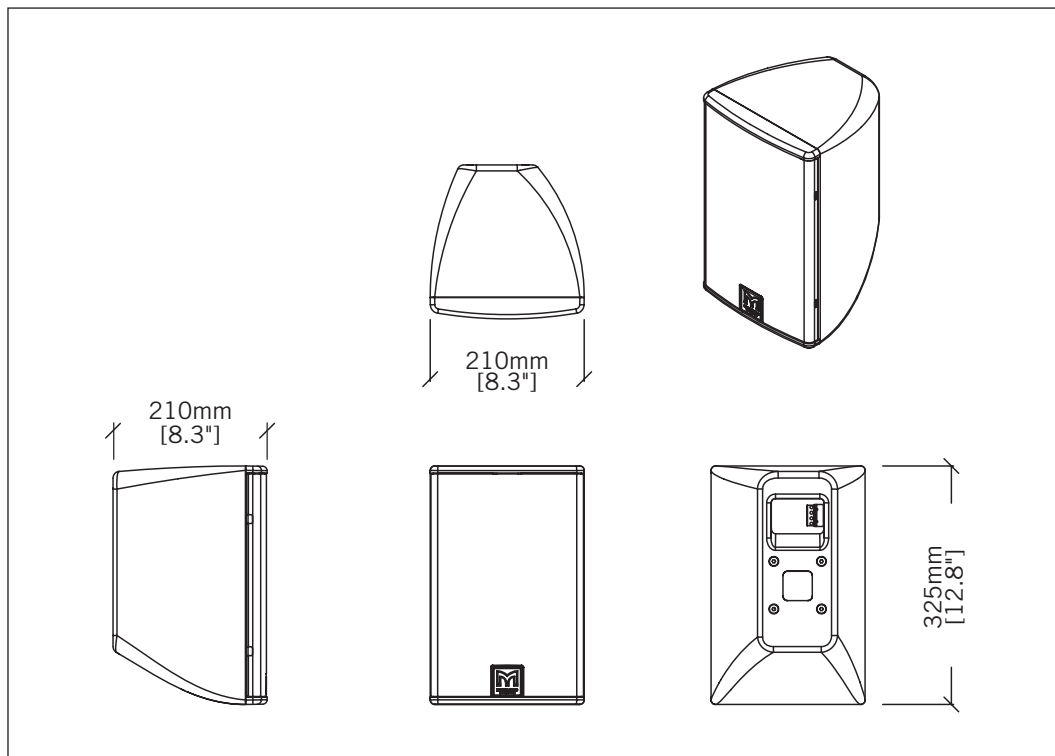

CDD8

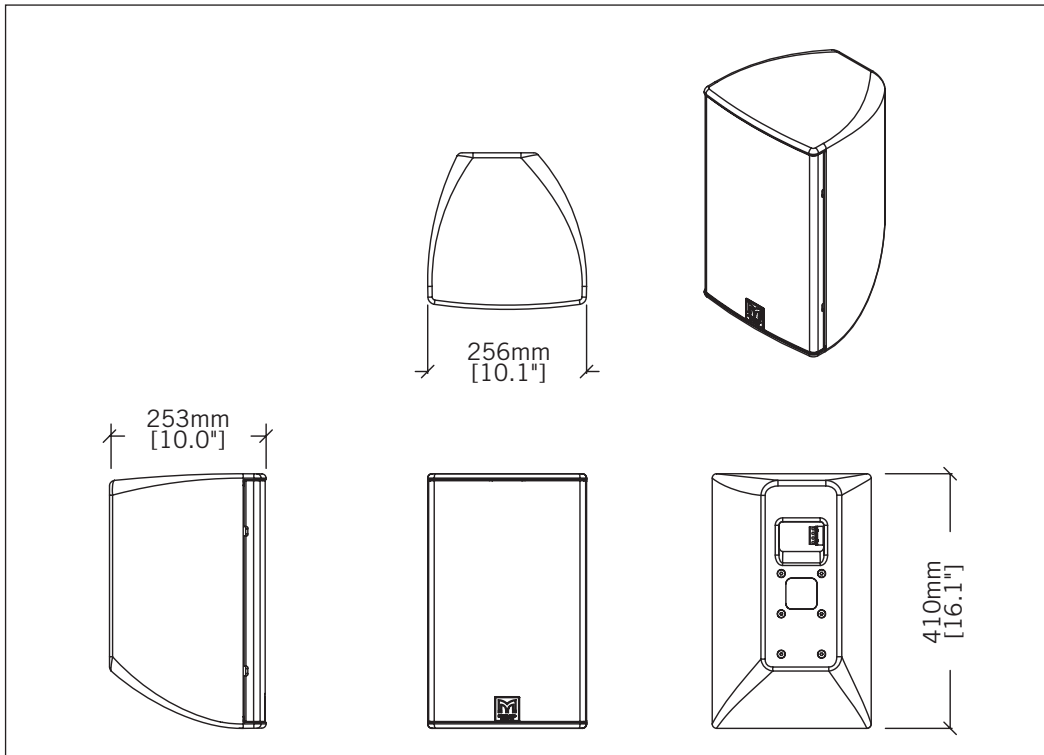

CDD10

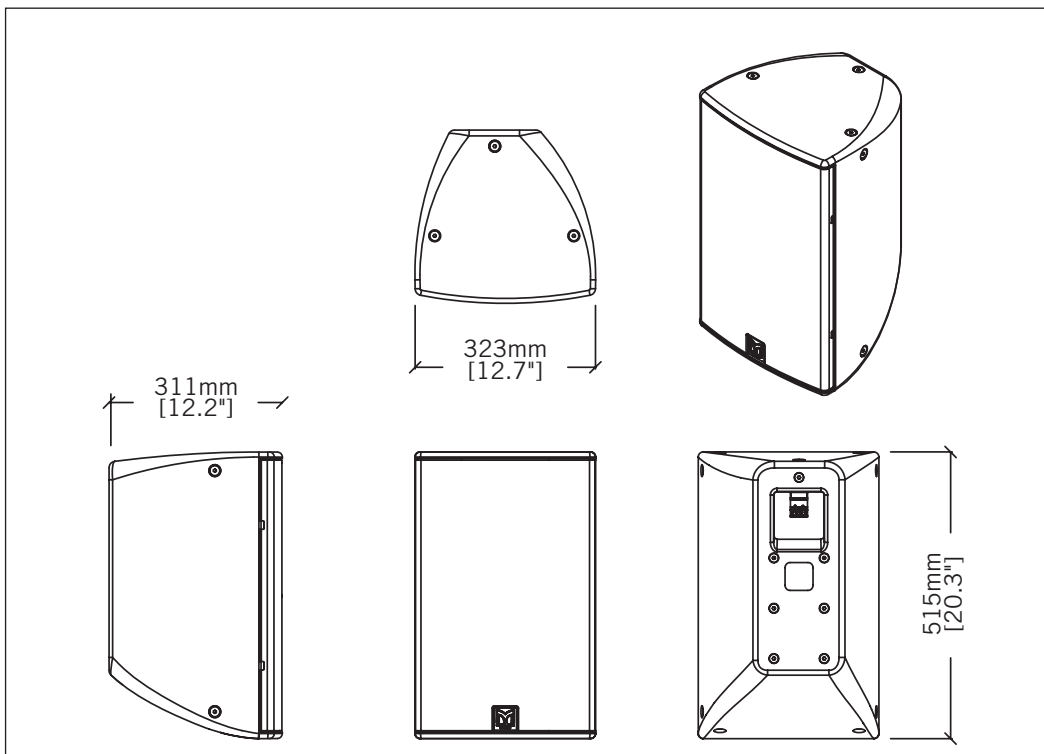

**CDD12**

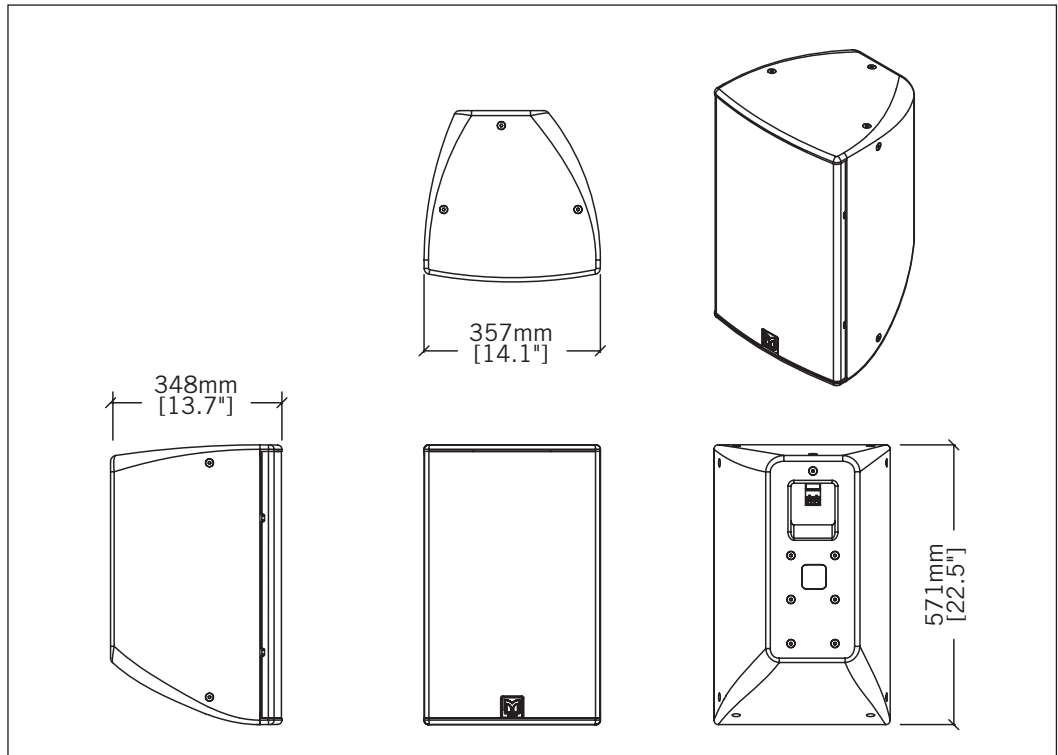

**CDD15**

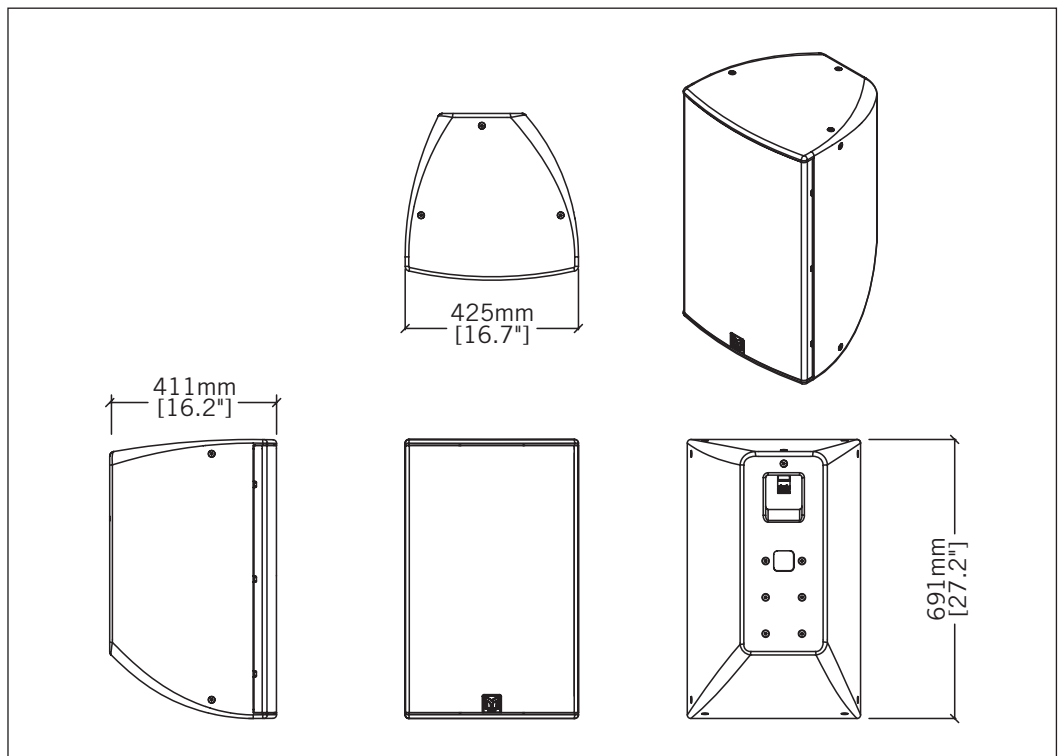

SX112

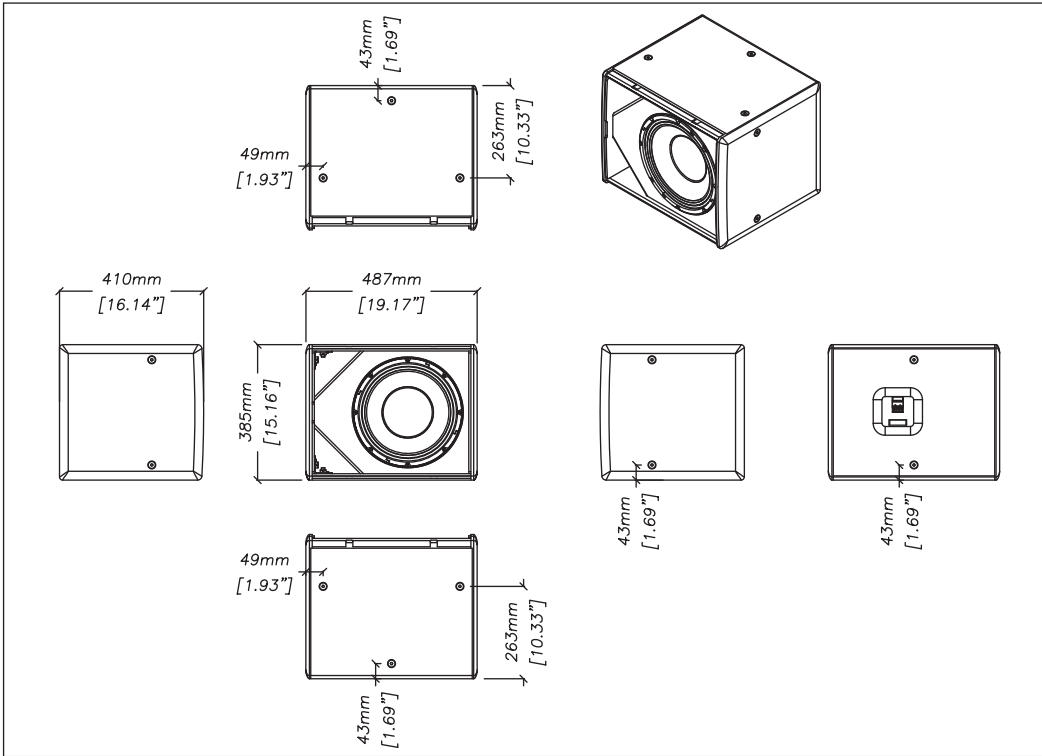

SX212

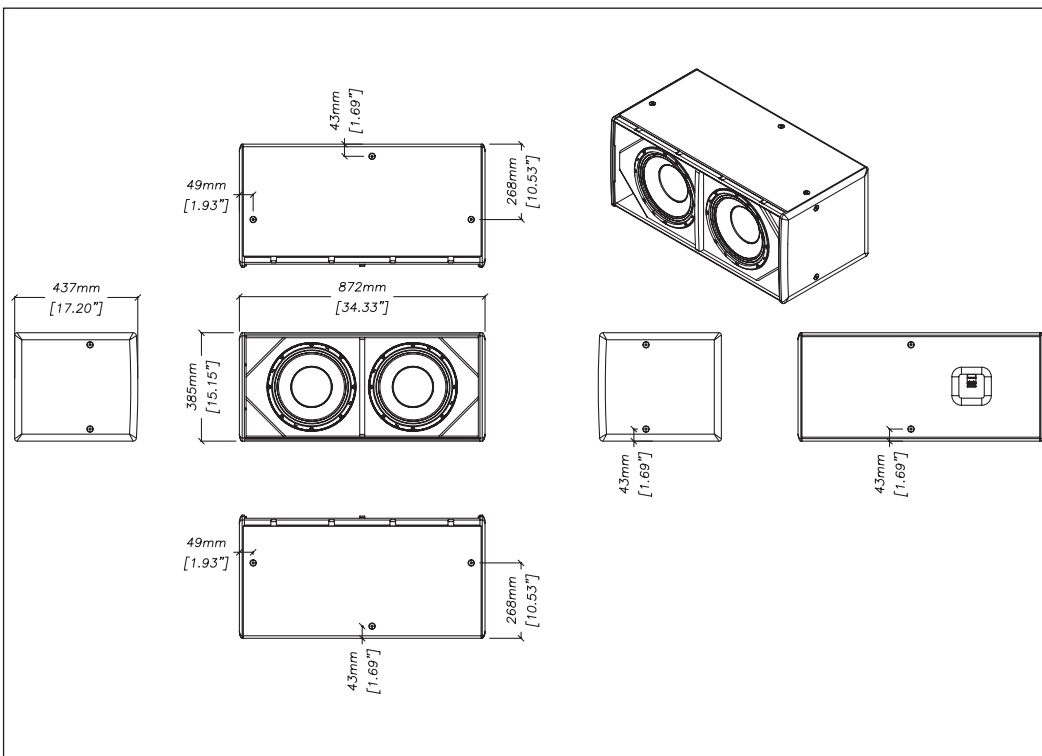

SX118

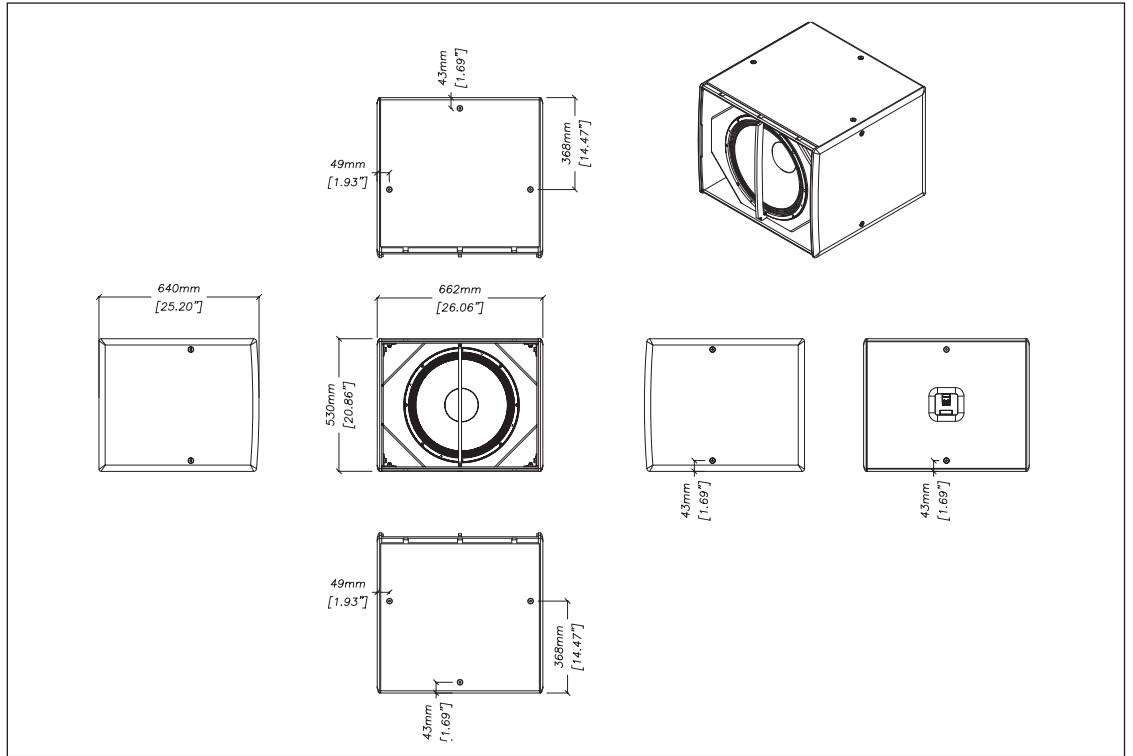

SX218

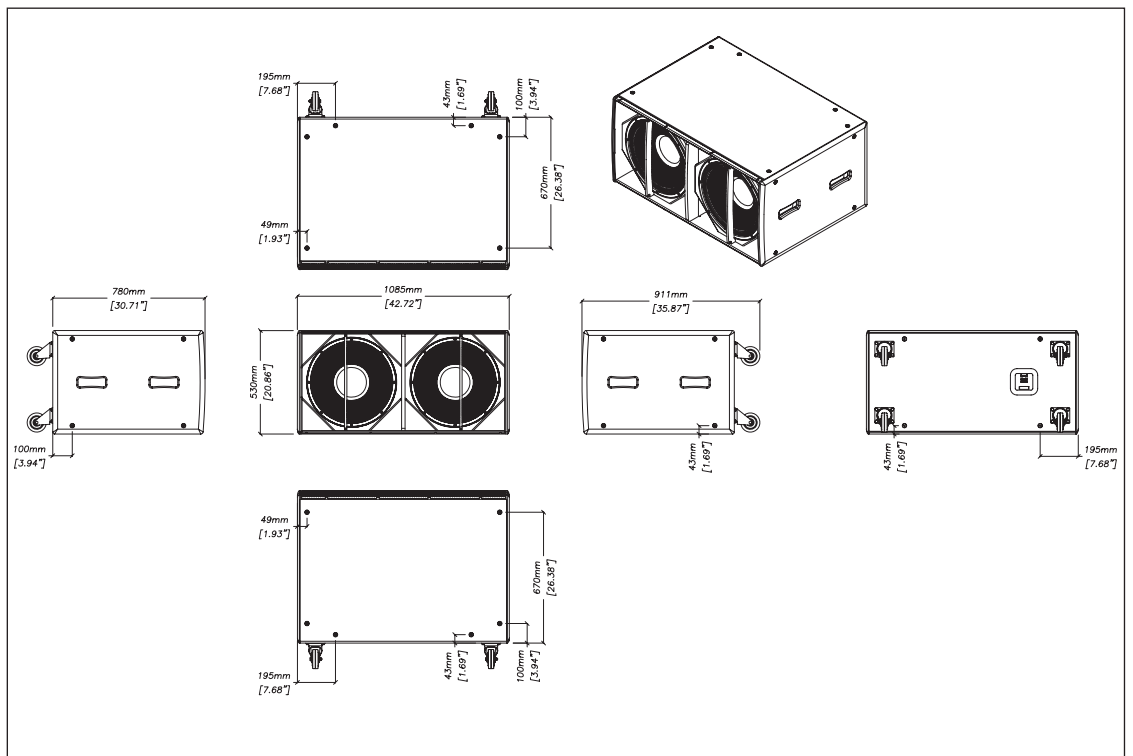

## SPEAKER BRACKETS

### CDD5 Wall Bracket

- Bracket supplied with the speaker. The replacement part is ASM10001 for white or ASM10002 for black
- Vertical and horizontal tilt and pan
- Weatherised for outdoor installation

Here is the arrangement of the four screw holes in the wall (measurements shown in mm):

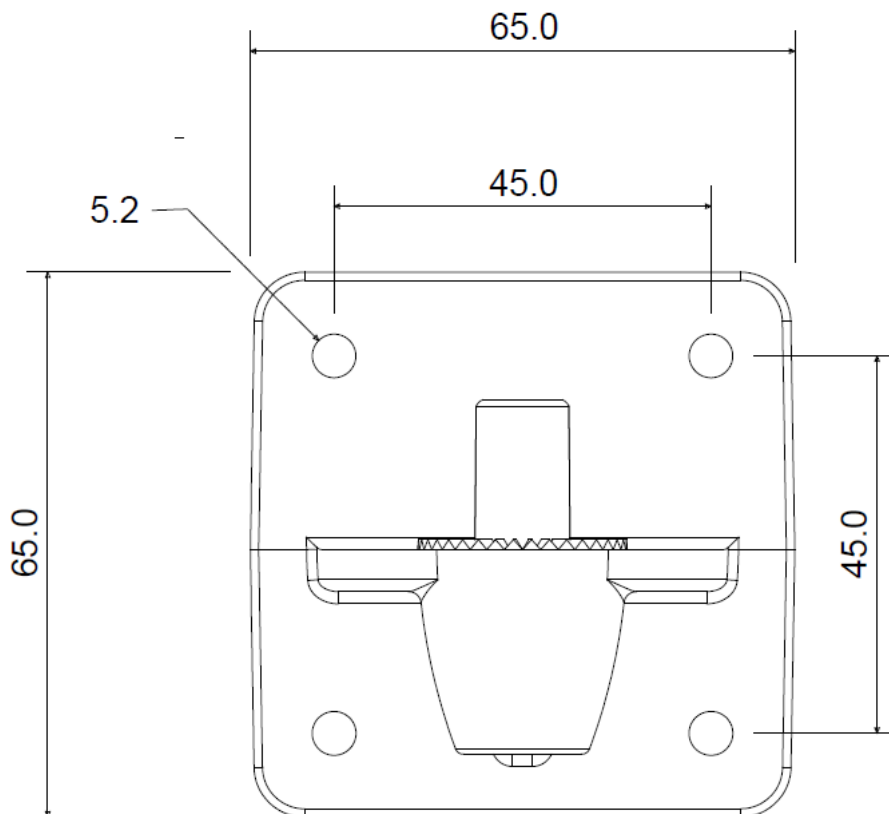

**CDD5 Ceiling Bracket**

Here is the arrangement of the three screw holes in the ceiling (measurements shown in mm) and the length of the bracket:

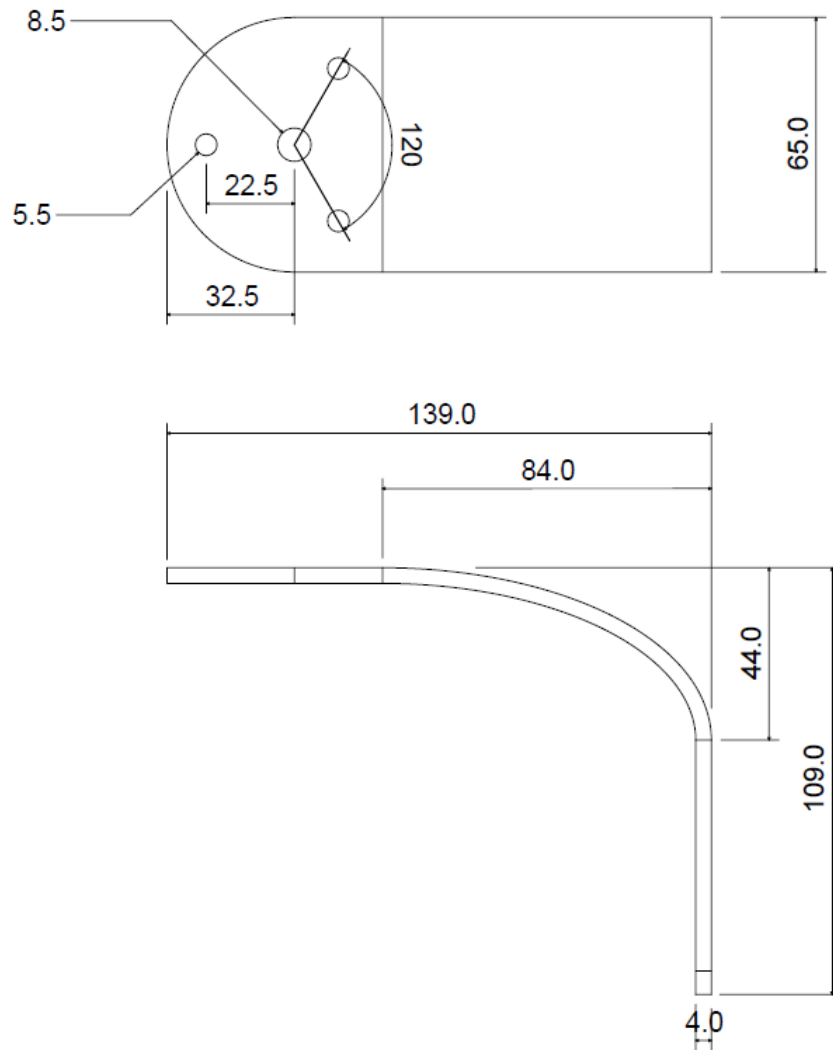

**CDD6 & CDD8 Wall Bracket**

Here is the arrangement of the four screw holes in the wall:

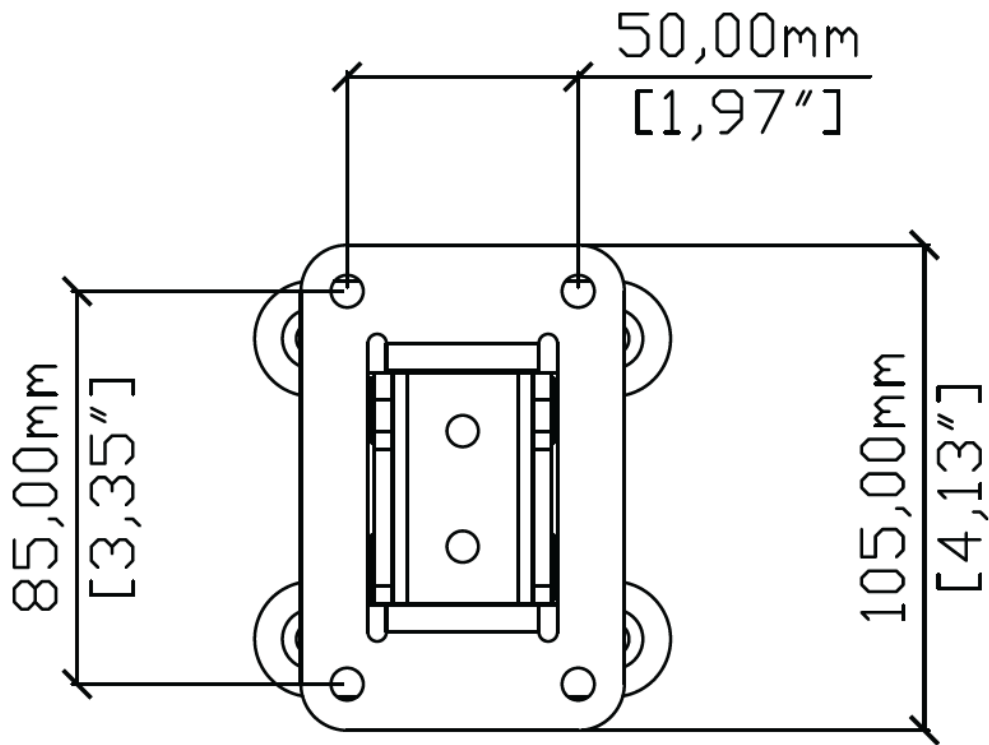



### CDD6 & CDD8 Ceiling Bracket

Here is the arrangement of the three screw holes in the ceiling (measurements shown in mm) and the length of the bracket:

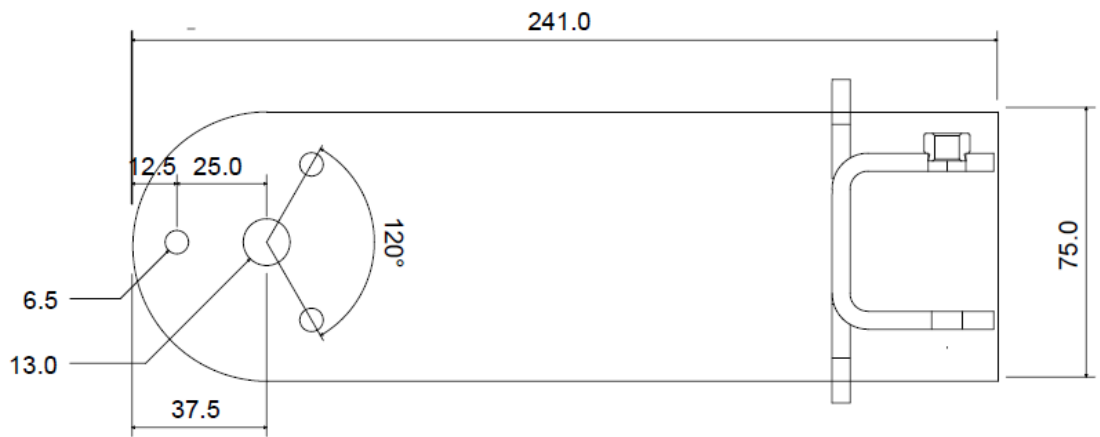

**CDD10 & CDD12 Wall Bracket**

Here is the arrangement of the four screw holes in the wall:

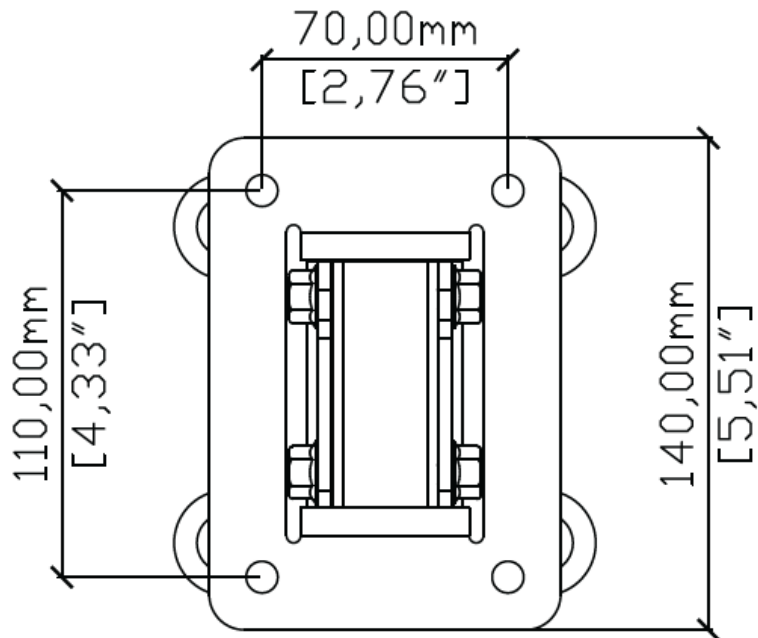
**CDD15 Wall Bracket**

Here is the arrangement of the six screw holes in the wall:

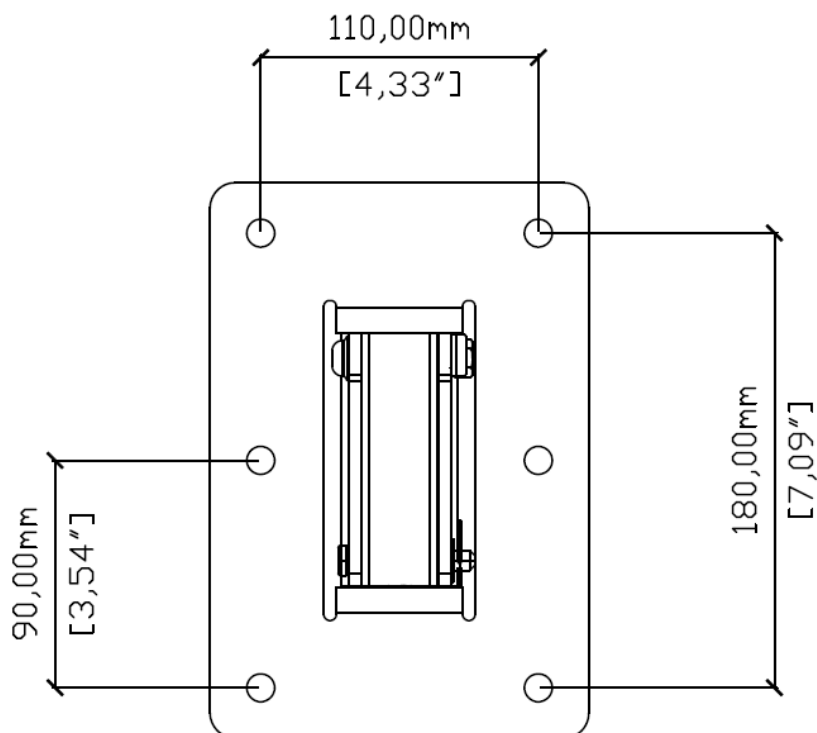



## WARRANTY

Martin Audio CDD and SX Series Loudspeakers are warranted against manufacturing defects in materials or craftsmanship over a period of 5 years from the date of original purchase.

During the warranty period Martin Audio will, at its discretion, either repair or replace products which prove to be defective provided that the product is returned in its original packaging, shipping prepaid, to an authorised Martin Audio service agent or distributor.

Martin Audio Ltd. cannot be held responsible for defects caused by unauthorised modifications, improper use, negligence, exposure to inclement weather conditions, act of God or accident, or any use of this product that is not in accordance with the instructions provided by Martin Audio. Martin Audio is not liable for consequential damages.

This warranty is exclusive and no other warranty is expressed or implied. This warranty does not affect your statutory rights.

## COPYRIGHT AND TRADEMARKS

Copyright Martin Audio Ltd. Martin Audio, CDD Series and SX Series are trademarks of Martin Audio Ltd and are registered in the United Kingdom, United States and other countries.

All other trademarks and trade names are the property of their respective owners.

Copyright © 2024 Martin Audio Limited. All rights reserved.

**Martin Audio Limited**

**Century Point**

**Halifax Road**

**Cressex Business Park**

**High Wycombe**

**Buckinghamshire**

**HP12 3SL**

**England**

**UK**

**+44 1494 535 312**

**info@martin-audio.com**

**NORTH AMERICA**

**+1 323-381-5310**

**ussupport@martin-audio.com**

All information is Copyright © 2024 Martin Audio Ltd.

Martin Audio, the Martin Audio logo and CDD are registered trademarks of Martin Audio Ltd. in the United Kingdom, United States and other countries; all other Martin Audio trademarks are the property of Martin Audio Ltd.

All other trademarks and trade names are the property of their respective owners.

[www.martin-audio.com](http://www.martin-audio.com)